



HECKLER & KOCH

NO COMPROMISE

G36

ELECTRIC AIRSOFT / cal. 6 mm

powered by **UMAREX**® www.umarex.com

UMAREX HOLDS THE WORLDWIDE EXCLUSIVE HK-TRADEMARK AND EXTERIOR DESIGN COPY LICENSE FOR USE WITH THIS UMAREX PRODUCT, GRANTED BY HK, INC., U.S.A.



EN Operating instructions 2 - 8 | **DE** Bedienungsanleitung 9 - 15

FR Mode d'emploi 16 - 22 | **ES** Manual de instrucciones 23 - 29



SAFE WEAPON HANDLING



DESCRIPTION



OPERATION



MAINTENANCE



SAFETY INSTRUCTIONS

You should be fully familiar with the proper and safe handling of your weapon. The basic principles of weapons safety require you to always apply the following rules when handling the firearm.

- Always treat a weapon as if it was loaded.
- Always put the safety of a weapon to „safe“ when loading it so that there can be no unintentional discharge.
- Keep your finger away from the trigger, it should be straight and should rest on the trigger guard.
- Only use the kind of projectiles suitable for your weapon.
- Always keep the muzzle pointed in a safe direction.
- This weapon may only be discharged in your own house, on authorized shooting ranges and inside enclosed private property. It is to be made sure that no projectile can leave the enclosed property.
- Keep the danger area of the projectile.
- Never transport a loaded weapon. Only load your weapon when you intend to fire it.
- Never aim your airgun at persons or animals. Avoid ricochets. Never fire at smooth, hard surfaces or water.
- Before you discharge your weapon, make sure that target and surrounding area are safe.
- Make sure that you always have full control over the muzzle of your weapon, even if you stumble or fall down.
- Safety shooting glasses should always be worn when firing the weapon.
- Always store your weapon in a safe place and in unloaded condition. Unauthorized persons (persons not familiar with the use of weapons, children) must not have access to it, ammunition is to be kept in a separate place.
- This weapon and its instruction manual may only be passed on to persons
 - who are fully familiar with its use and
 - who have reached the legally stipulated minimum age in the respective country.
- Modifications or repairs of weapons are only to be effected by authorized agencies or by a skilled gunsmith.
- Never leave a loaded weapon unattended.
- Only unloaded weapons are to be handed over to another person.

WARRANTY

The Umarex company will repair or replace your weapon free of charge (up to 12 months from date of purchase) provided the defect was not caused by you. Return the gun to the authorised dealer from where you bought it.



SAFETY INSTRUCTIONS



MAINTENANCE



DESCRIPTION

EN



CAUTION

Carefully read and understand these instructions before using this weapon. Buyers and users must follow the instructions for the safe use of airguns.
Any change or conversion of this weapon will lead to a different classification of the weapon in respect of the appropriate firearms legislation and are therefore illegal. In such cases, the manufacturer's warranty becomes immediately null and void.



WARNING

Do not brandish or display this airgun in public - it may confuse people and may be a crime. Police and others may think this airgun is a firearm. Do not change the coloration and markings to make it look more like a firearm. That is dangerous and may be a crime.

REPAIR

A gun, that does not work properly is dangerous. Repairing a gun by oneself is difficult and an incorrectly assembled gun can malfunction in dangerous ways.

Caution: Repairs should only be completed by UMAREX authorised centres.

TECHNICAL DATA

Item no.

2.5746 | 2.5747 | 2.5748

System:

Electric Airsoft

Caliber/Ammo:

cal. 6 mm BB

Energy:

> 1,0 JOULE

Velocity:

up to 120 m/s with 0,20 g BB

barrel length:

540 mm | 400 mm | 270 mm

Length:

1015 mm | 872 mm | 720 mm

Weight:

3330 g | 2985 g | 2795 g

Magazine capacity:

470 BBs

Dangerous area up to:

150 m

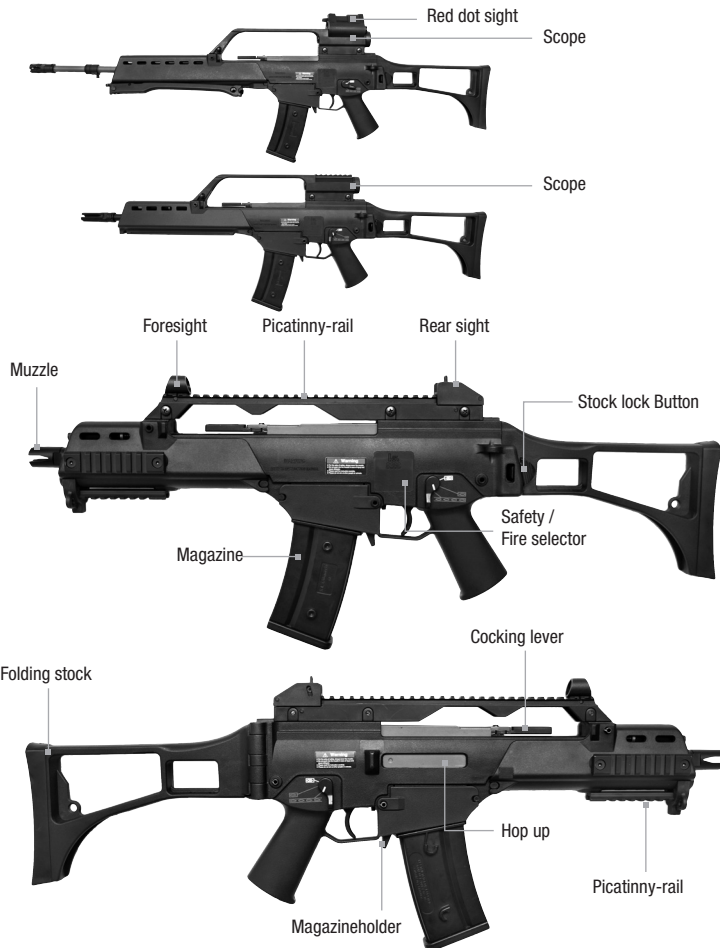

EN



SAFETY

CAUTION

Only handle the weapon when it is in its safe condition.
Always make sure that the muzzle points into a safe direction.



SAFE

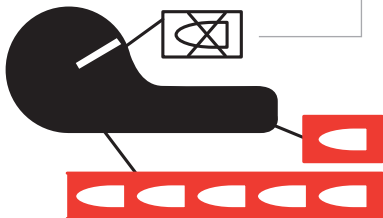

SHOOTING

CAUTION

Do not switch the fire selector while pulling the trigger. This causes severe damage to your weapon.

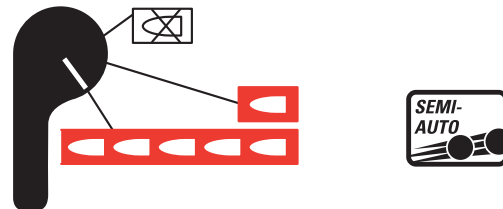
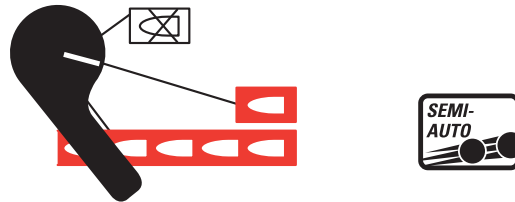



INLAYING RECHARGEABLE BATTERY

EN

CAUTION

When batteries are almost empty they can cause gearbox malfunctions that require repair. Batteries should never be overdischarged. This can damage the cell. Prolonged overcharging causes permanent damage to batteries. The battery should always be drained before charging. There is no warranty for batteries, because they are wear parts. Use only those batteries of 8,4 V

Please note that flat batteries must not be put in the household waste. Dispose of them properly, hand them in at your local shop for disposal or take them to a used battery collection location.

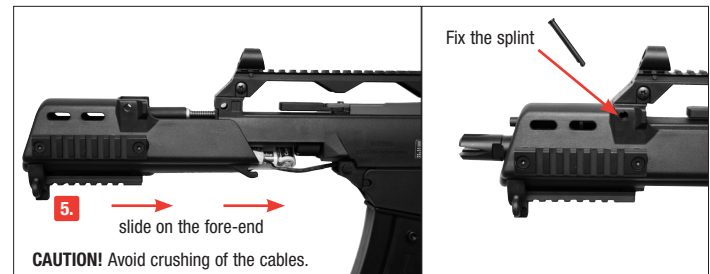
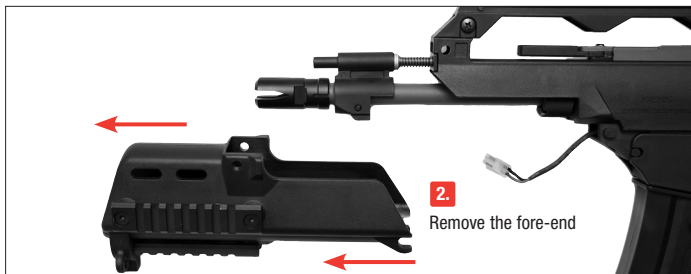
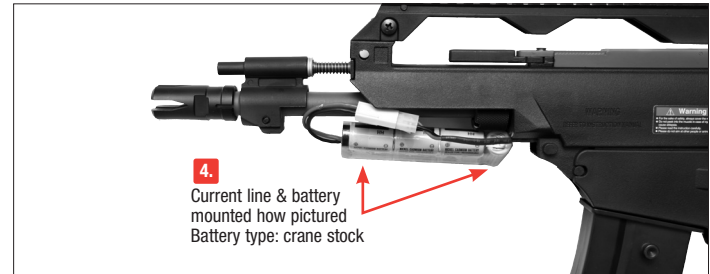
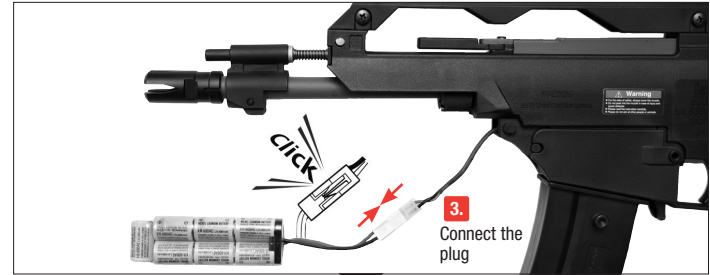

EN



LOAD THE MAGAZINE

CAUTION



Only use flawless BBS. Never use the following BBS:

1 diameter larger than 6mm, 2 with edges, 3 both halves not aligned, 4 used, soiled. Warranty expires if non-recommended BBS are used.

It's recommended to use precision BBS from UMAREX/Walther.

To ensure proper operation of the magazine, protect it from dirt and dust.

470
ROUNDS

WEIGHT
0,2 g BB

6 mm
AIRSOFT

WEIGHT
0,25 g BB



1.

push magazineholder

2.



5.

Click

3.

min. 50 BBS



4.

rotate for cock



ADJUSTABLE REARSIGHT

EN





Elevation adjustment G36C

Shoot too far high:



Shoot too far low:





Windage adjustment G36C

Shoot too far right:

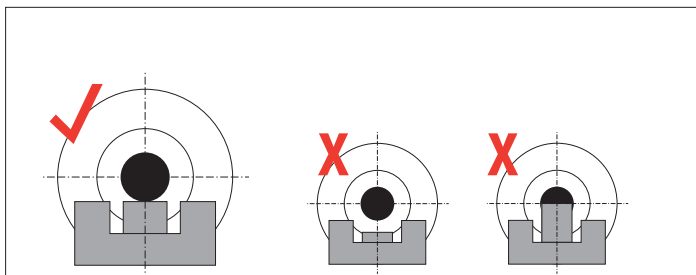

Shoot too far left:

Scope magnification 3,5 x

Elevation adjustment G36K / G36

Shoot too far high:



Shoot too far low:





Windage adjustment G36K / G36

Shoot too far right:

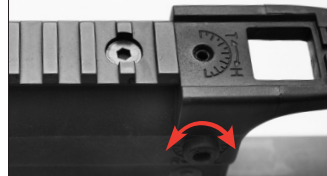

Shoot too far left:

G36 Red dot sight

Elevation adjustment

Shoot too far high:



Shoot too far low:

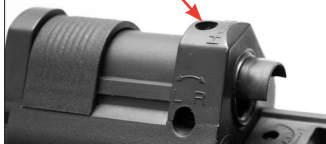





Windage adjustment

Shoot too far right:

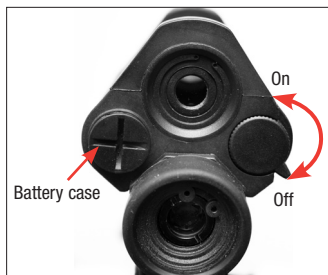

Shoot too far left:

CAUTION: Never look through the scope directly into the sun!

 +
- Battery: 2x Lady N/1,5V Alkaline

Please note that flat batteries must not be put in the household waste. Dispose of them properly, hand them in at your local shop for disposal or take them to a used battery collection location.

EN



ADJUSTABLE SHOOT UP

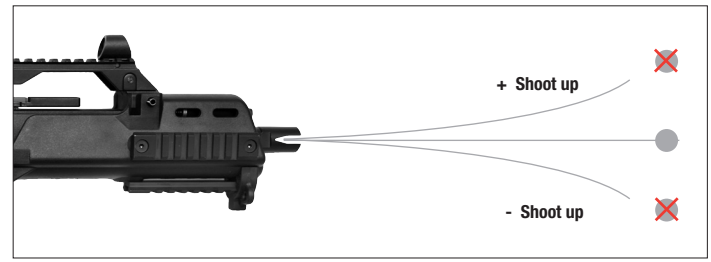
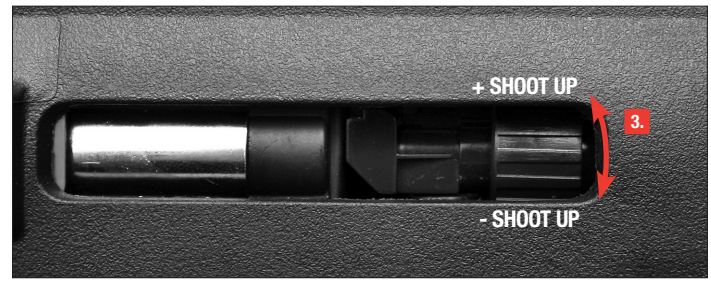

BARREL CLEANING

CAUTION

- Adjust the shoot up in normal position, before cleaning the weapon.
 - Do not force the rod into the barrel, as this could cause damage.
 - Never drip silicone oil directly into the barrel.
- When airsoft gun is stored over a longer period without any use please make sure the battery is disconnected from the gun and push the release button before.

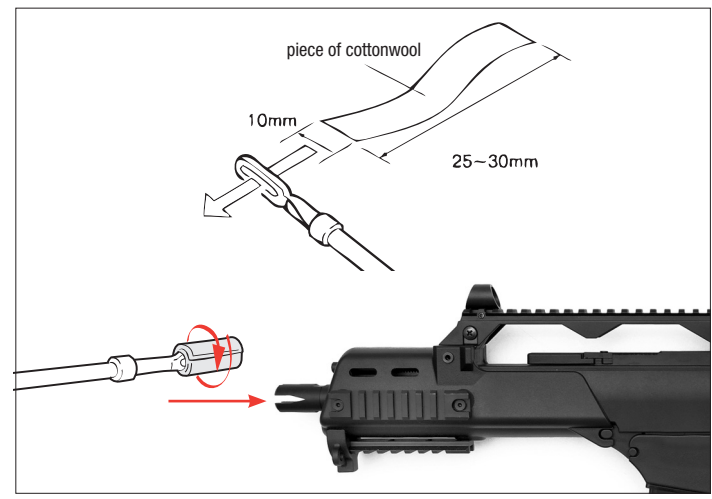

Put the safety on „safe“ and remove the magazine. Prepare a thin rod with a length of approx. 60 cm. Attach a piece of cotton fabric to its end and clean the barrel with some silicone oil.



SICHERER UMGANG MIT WAFFEN

DE



BENENNUNG



BEDIENUNG



PFLEGE



SICHERHEITSHINWEISE

Sie sollten mit der richtigen, sicheren Handhabung Ihrer Waffe vertraut sein. Im Hinblick auf die Grundregeln zum sicheren Schießen bedenken Sie, dass jede Berührung mit der Waffe als Handhabung verstanden wird.

- Behandeln Sie jede Waffe so, als wäre sie geladen.
- Die Waffe beim Laden stets sichern, so dass sich kein Schuss ungewollt lösen kann. Finger immer außerhalb des Abzugsbügels halten und nur zum Schuss an den Abzug legen.
- Verwenden Sie nur für diese Waffe vorgesehene Geschosse.
- Halten Sie die Mündung stets in eine sichere Richtung.
- Das Schießen ist nur in der eigenen Wohnung, auf polizeilich zugelassenen Schießständen und im befriedeten Besitztum erlaubt, wenn das Geschoss dieses beim Schuss nicht verlassen kann. Hierbei den Gefahrenbereich des Geschosses beachten.
- Transportieren Sie niemals eine geladene Waffe. Laden Sie nur, wenn Sie schießen möchten.
- Waffe niemals auf Menschen oder Tiere richten. Vermeiden Sie Querschläger. Schießen Sie niemals auf glatte, harte Oberflächen oder auf Wasserflächen.
- Vergewissern Sie sich vor dem Schuss, dass Ziel und Umgebungsbereich sicher sind.
- Kontrollieren Sie immer, ob die Waffe ungeladen ist, wenn Sie sie transportieren oder von einer anderen Person übernehmen.
- Vergewissern Sie sich, dass Sie, auch beim Stolpern oder Stürzen die Richtung der Mündung kontrollieren können.
- Aus Sicherheitsgründen sollte beim Schießen eine Schutzbrille getragen werden.
- Aufbewahren der Waffe stets sicher und ungeladen vor unerlaubtem Zugriff Unbefugter (ungeschulte Personen, Kinder, Personen unter 18 Jahren) und getrennt von der Munition.
- Weitergabe dieser Waffe mit der Bedienungsanleitung nur an Personen
 - die mit der Handhabung dieser Waffe genauestens vertraut sind und
 - die über das entsprechende Mindestalter nach dem Waffengesetz in dem jeweiligen Land verfügen.
- Jegliche Veränderungen oder Reparaturen von Waffen sollten nur von fachkundigen Firmen oder vom Büchsenmacher durchgeführt werden.
- Legen Sie niemals eine geladene Waffe aus der Hand.
- Geben Sie nur entladene Waffen an andere Personen weiter.

GARANTIE

Innerhalb eines Jahres ab Kaufdatum repariert oder ersetzt Ihnen die Fa. Umarex Ihre Waffe kostenlos, falls der Defekt nicht durch Eigenverschulden aufgetreten ist. Geben Sie die Waffe einem autorisierten Händler, beschreiben Sie ihm das Problem und fügen Sie den entsprechenden Kaufbeleg bei.



ACHTUNG

Zu Ihrer eigenen und zur Sicherheit anderer lesen Sie die Bedienungsanleitung vollständig und sorgfältig durch, bevor Sie mit der Waffe den ersten Versuch zu Schießen unternehmen. Käufer und Besitzer haben die Pflicht, alle Regeln über den Gebrauch und den Besitz von Druckluftwaffen zu befolgen. Jede Änderung an dieser Waffe kann zu einer Änderung der waffenrechtlichen Einstufung führen und ist somit unzulässig. Die Gewährleistung des Herstellers erlischt in diesem Fall sofort.

WARNUNG

Diese Druckluftwaffe nicht in der Öffentlichkeit zeigen oder mit ihr drohen - es führt zu Verwechslungen mit echten Waffen und gilt als Straftat. Ändern Sie keinesfalls die Farbe und Markierungen der Druckluftwaffe, um ihr Aussehen mehr einer realen Schusswaffe anzugleichen. Dies ist gefährlich und kann als Straftat gelten.

REPARATUR

Eine Waffe, die nicht einwandfrei funktioniert, ist gefährlich. Es ist schwierig, eine Waffe selbst zu reparieren, und falscher Zusammenbau kann zu gefährlichen Funktionsstörungen führen. Achtung: Lassen Sie die Waffe nur von einem autorisiertem Fachhändler/ Büchsenmacher überprüfen und reparieren.

TECHNISCHE DATEN

Art. Nr.	2.5746 2.5747 2.5748
System:	Electric Airsoft
Kaliber/Munition:	cal. 6 mm BB
Energie:	> 1,0 JOULE
Geschwindigkeit:	bis 120 m/s mit 0,20 g BB
Laufänge:	540 mm 400 mm 270 mm
Gesamtlänge:	1015 mm 872 mm 720 mm
Gewicht:	3330 g 2985 g 2795 g
Magazinkapazität:	470 BBs
Gefahrenbereich max.:	150 m





SICHERUNG



ACHTUNG

Hantieren Sie nur mit der Waffe, wenn diese gesichert ist.
Achten Sie stets darauf, dass die Mündung in eine sichere Richtung zeigt.



SAFE

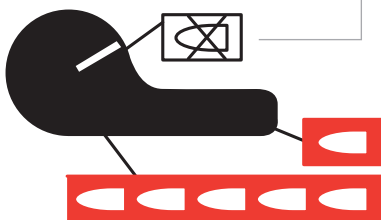

SCHIESSEN

DE



ACHTUNG

Schalten Sie niemals, während Sie den Abzug betätigen, den Feuerwahlhebel um. Dies verursacht schwere Schäden an Ihrer Waffe.

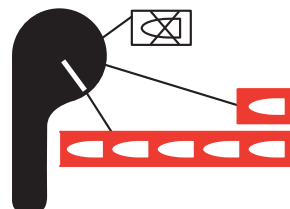
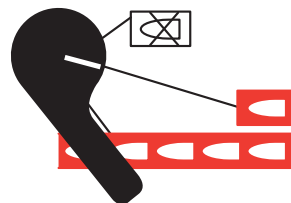



! ACHTUNG

Bei fast leeren Akkus kann es zu Gearbox-Störungen kommen, welche reparaturbedürftig sind. Akkus dürfen nicht tiefentladen werden, sonst können die Zellen beschädigt werden. Längeres Überladen verursacht dauerhaften Schaden der Akkus. Akkus sollten vor dem Laden stets entladen sein. Auf Akkus kann keine Garantie gewährt werden, da sie Verschleißteile sind. Verwenden Sie nur einen Akkutype von mindestens 8,4 V.

Verbrauchte Batterien gehören nicht in den Hausmüll. Lassen Sie diese nur über den Fachhandel oder durch Batterie-Sammelstellen entsorgen.

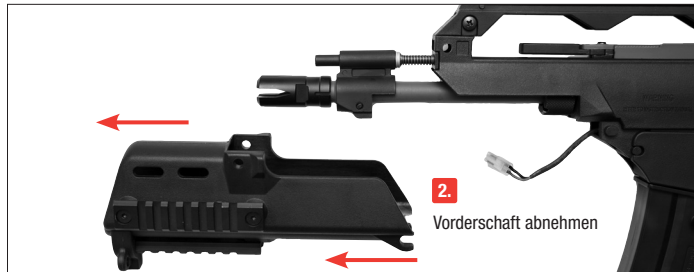
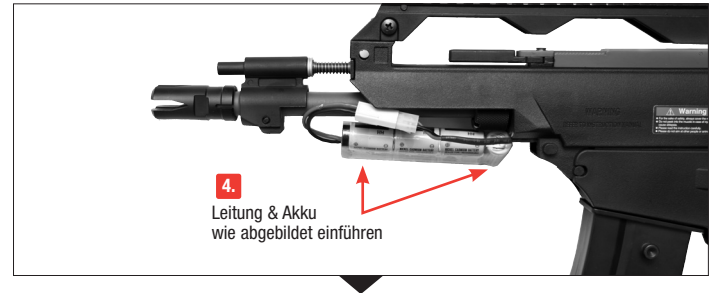
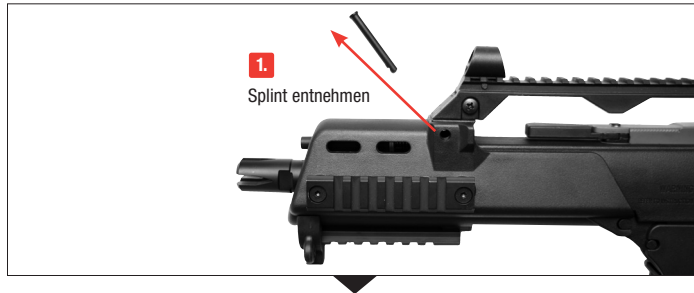
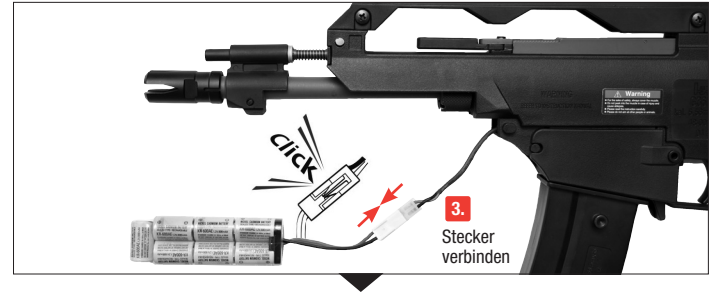

Splint befestigen



MAGAZIN LADEN

DE

ACHTUNG



Verwenden Sie nur einwandfreie BB-Kugeln: \varnothing 6 mm.

Verwenden Sie auf keinen Fall folgende BB-Kugeln:

❶ Durchmesser größer als 6 mm, ❷ mit Grat, ❸ versetzte Hälften, ❹ gebraucht, verschmutzt.

Bei Gebrauch ungeeigneter Geschosse erlischt die Garantie. Empfohlen werden Präzisionsrundkugeln des Herstellers Umarex/Walther. Vermeiden Sie das Eindringen von Schmutz und Staub in das Magazin.

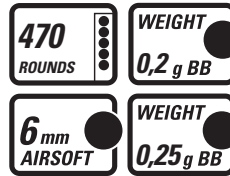

3. mind. 50 BBs



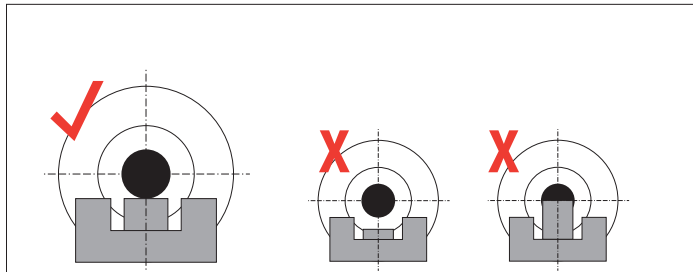
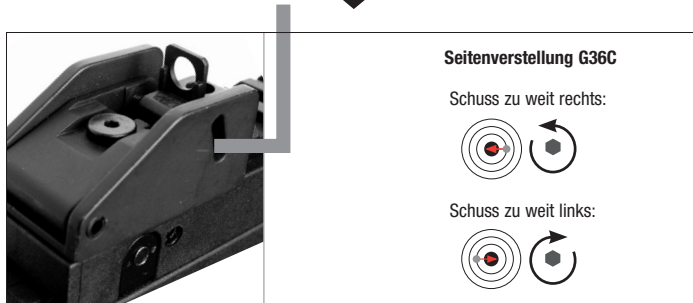
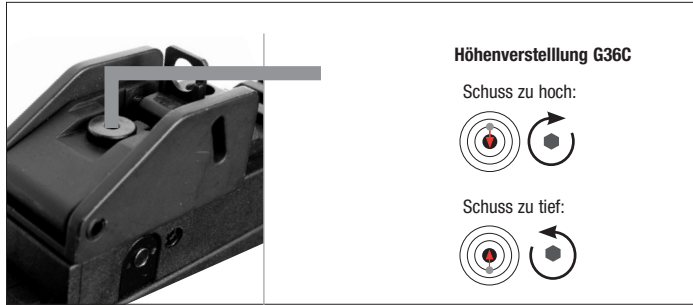

Zielfernrohr 3,5 x Vergrößerung



G36 Rotpunktvisier

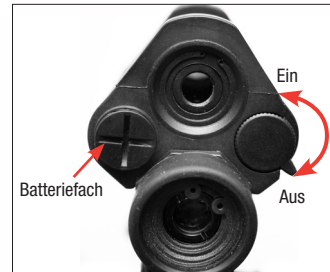
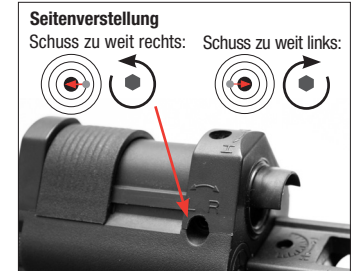
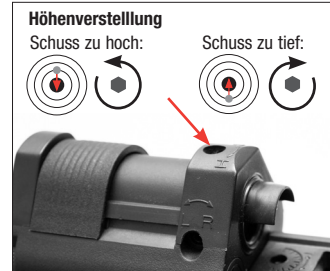

Achtung: Schauen Sie niemals durch das Zielfernrohr direkt in die Sonne!

+
- Batterie: 2x Lady N/1,5V Alkaline

Verbrauchte Batterien gehören nicht in den Hausmüll. Lassen Sie diese nur über den Fachhandel oder durch Batterie-Sammelstellen entsorgen.



SHOOT UP EINSTELLEN

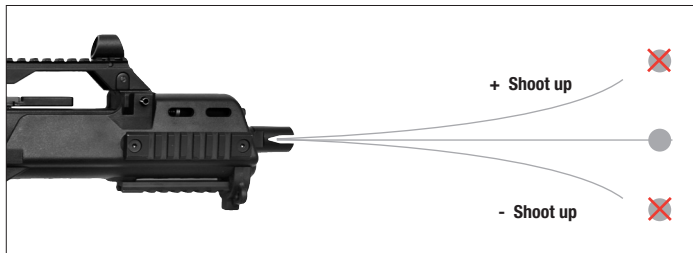
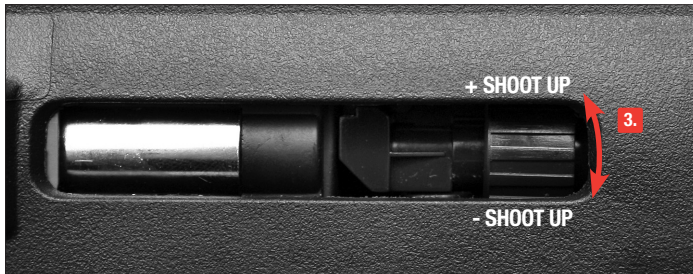

LAUFREINIGUNG

DE



ACHTUNG

- Vor dem Reinigen der Waffe das shoot up wieder auf Normal einstellen.
- Schieben Sie den Stab niemals mit Gewalt in den Lauf, dies kann Beschädigungen verursachen.
- Geben Sie niemals das Waffen-Öl direkt in den Lauf.
- Bei längerer Lagerung der Airsoft Waffe, den Akku abklemmen und den Entspannkopf drücken.

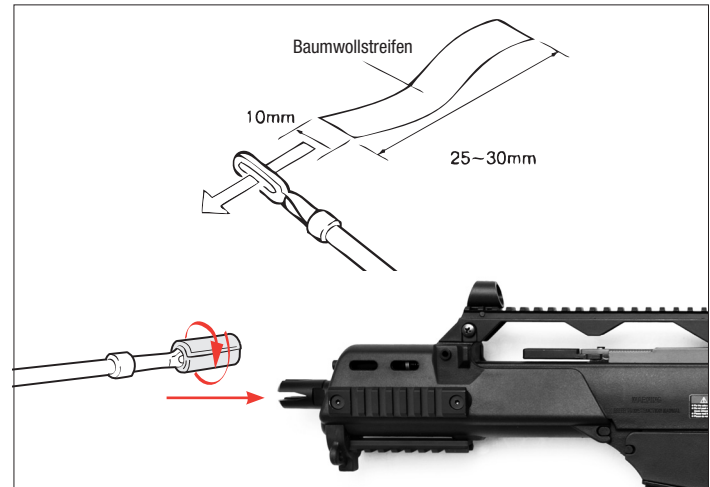

Sichern Sie die Waffe. Entnehmen Sie das Magazin. Nehmen Sie einen dünnen ca. 60 cm langen Stab. Wickeln Sie ein Stück Baumwolltuch um das Ende, benetzen Sie das Tuch mit etwas Waffen-Öl und reinigen Sie damit den Lauf.



MANIEMENT DES ARMES EN TOUTE SÉCURITÉ



DESIGNATION



UTILISATION



ENTRETIEN



INSTRUCTIONS DE SÉCURITÉ

Vous devrez savoir manier votre arme correctement et sans danger. En ce qui concerne les règles de base de tir en toute sécurité, considérez que chaque contact avec l'arme fait partie de son maniement.

- Maniez toujours l'arme comme si elle était chargée.
- Mettez toujours la sûreté avant de charger l'arme afin d'éviter tout tir involontaire.
- Ne mettez pas le doigt sur la détente et ne l'y placez que lorsque vous allez tirer.
- N'utilisez que les projectiles prévus pour cette arme.
- Pointez toujours la bouche de l'arme dans une direction non dangereuse.
- Il n'est permis de tirer avec l'arme que sur le lieu de résidence du propriétaire ou dans des zones de tir autorisées par la police, à condition que le projectile ne puisse pas sortir de la zone de tir. Veuillez toujours prendre en compte la zone de danger maximale du projectile.
- Ne transportez jamais l'arme lorsqu'elle est chargée. Ne la chargez que lorsque vous vous apprêtez à tirer.
- Ne dirigez jamais l'arme vers des personnes ni des animaux. Évitez les tirs pouvant faire ricocher le projectile. Ne tirez jamais sur des surfaces planes et dures, ni sur une surface d'eau car les projectiles peuvent ricocher.
- Avant de tirer, assurez-vous que l'objectif et les alentours ne présentent pas de danger.
- Vérifiez toujours que l'arme est déchargée avant de la transporter ou de la remettre à autrui.
- Veillez à maîtriser la direction dans laquelle la bouche de l'arme est pointée, même si vous trébuchez ou tombez.
- Pour des raisons de sécurité, portez des lunettes de protection lorsque vous tirez.
- Rangez toujours l'arme déchargée, séparée des munitions et dans un endroit sûr afin d'éviter que des personnes non autorisées (personnes non formées, enfants) puissent y avoir accès.
- Ne remettez cette arme, accompagnée du mode d'emploi, qu'à des personnes
 - qui sont le plus possible formées au maniement de cette arme et
 - qui ont atteint l'âge minimum légal selon la loi sur les armes en vigueur dans votre pays.
- Toute modification ou réparation de l'arme devra être effectuée par une entreprise spécialisée ou un armurier.
- Ne laissez jamais l'arme chargée sans surveillance.
- Déchargez toujours l'arme avant de la remettre à autrui.

RÉPARATIONS

Une arme qui ne fonctionne pas parfaitement est dangereuse. Il est difficile de réparer une arme soi-même, et un remontage incorrect peut entraîner des dysfonctionnements dangereux.

Attention : Seules des personnes spécialisées agréées ou un armurier peuvent contrôler et réparer l'arme.

GARANTIE

La société Umarex s'engage à réparer ou à remplacer votre arme, sans frais, sur une période de un an à partir de la date d'achat, à condition que l'utilisateur ne soit pas responsable du défaut. Veuillez remettre l'arme à un vendeur autorisé, décrivez-lui le problème et joignez le bon d'achat correspondant.



CONSIGNES DE SÉCURITÉ



ENTRETIEN



DÉSIGNATION DES PIÈCES

FR



ATTENTION

Pour votre sécurité et celle d'autrui, lisez attentivement la notice d'emploi avant d'utiliser l'arme pour la première fois. Les vendeurs, tout comme les acheteurs, ont l'obligation de respecter le règlement relatif à l'utilisation et à la possession d'armes à air comprimé. Il est interdit de procéder à toute modification de ce pistolet car cela pourrait entraîner un changement dans la classification correspondant à la législation sur les armes à feu. De plus, toute modification entraînerait l'annulation immédiate de la garantie du fabricant.



MISE EN GARDE

Mise en garde: N'exhibez pas cette arme à air comprimé et ne la sortez pas en public. Cela pourrait prêter à confusion ou être considéré comme un délit. Les membres des forces de sécurité et la police pourraient la prendre pour une vraie arme à feu. Ne changez pas sa couleur ni les éléments d'identification pour qu'elle ressemble plus à une vraie arme à feu. Cela serait dangereux et peut être considéré comme un délit.

Cette boîte contient: une réplique d'arme factice avec chargeur. Les AIR SOFT GUNS sont des modèles d'armes factices tirant des billes en plastique de 6 mm inoffensives. Ce modèle a une énergie comprise entre 0,08 joule et inférieure ou égale à 2 joules. En France, la vente de ces produits est réglementée par le décret n°99-240 du 24 mars 1999, qui interdit la distribution des modèles noirs ou chromés dont l'énergie est comprise entre 0,08 et 2 joules aux moins de 18 ans non accompagnés. Ce décret ne concerne pas les modèles transparents, les game guns (oranges) et les mini guns, dont la distribution reste donc autorisée aux mineurs.

- Distribution et vente interdite aux mineurs.
- **Attention: Ne jamais diriger le tir vers une personne.**

FICHE TECHNIQUE

Item no.	2.5746 2.5747 2.5748
Système :	Electric Airsoft
Calibre / Munitions :	cal. 6 mm BB
Énergie :	> 1,0 JOULE
Vitesse :	jusque 120 m/s avec 0,20 g BB
Longueur canon :	540 mm 400 mm 270 mm
Longueur :	1015 mm 872 mm 720 mm
Poids :	3330 g 2985 g 2795 g
Capacité:	470 BBs
Zone de danger au maximum :	150 m



FR



SÛRETÉ

ATTENTION

Ne manipulez l'arme lorsque le sécurité est enclenchée.
Assurez-vous que la bouche est orientée dans une direction non dangereuse.



SAFE

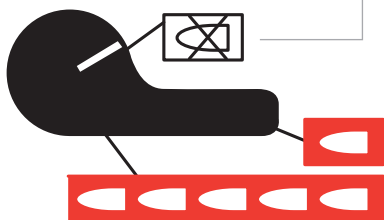

TIRER

ATTENTION

Pendant activé la détente, ne commutiez jamais le commutateur. Cela cause des dommages graves.

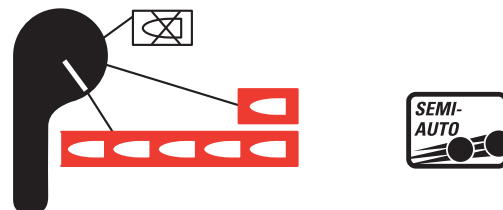
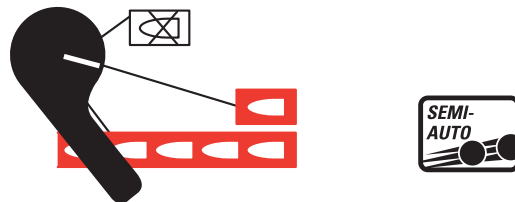



INSÉRER L'ACCU

FR

ATTENTION

Si les accus sont presque vides, des perturbations au niveau de la transmission pourraient en résulter qui rendent nécessaire une réparation.

Il ne faut pas décharger complètement les accus. Sinon, les cellules risquent d'être abîmées.

Toute surcharge de longue durée est susceptible d'abîmer les accus durablement.

Avant tout chargement, il faudrait que les accus soient toujours déchargés.

Nous ne pouvons pas accorder de garantie pour les accus, car ceux-ci représentent des pièces d'usure.

Veillez utiliser seulement le type d'accu ayant de du moins 8,4 V.

Vous ne devez pas jeter les piles usagées dans le conteneur à ordures ménagères. Déposez-les dans des commerces spécialisés ou à des points de collecte de piles.

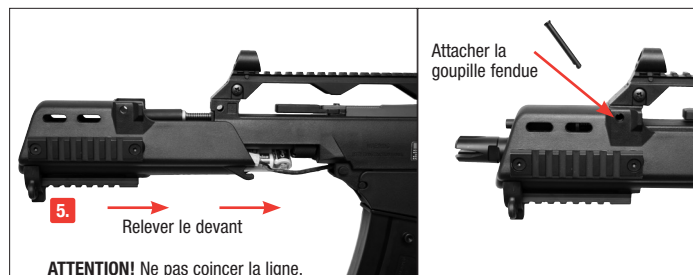
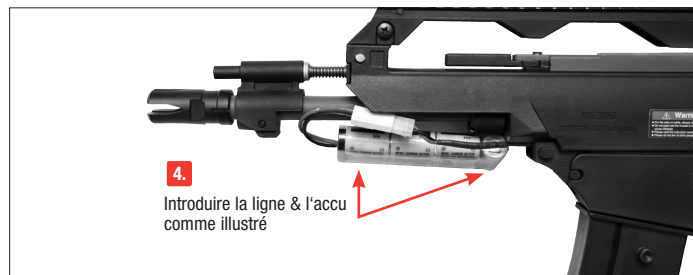
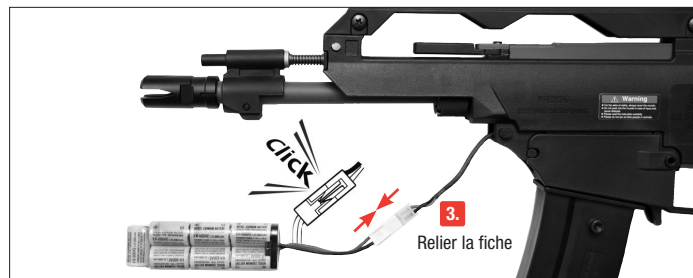
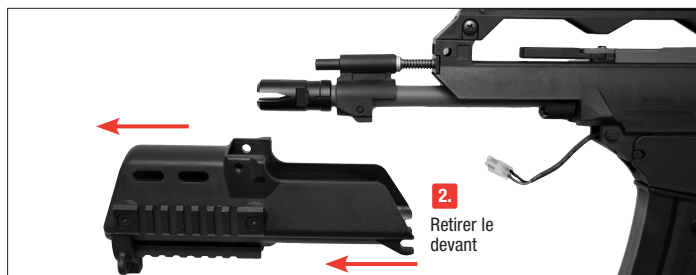
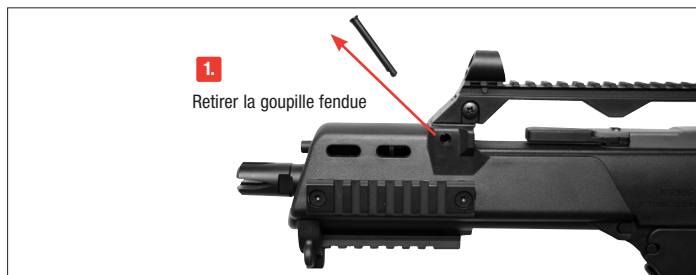

FR



APPUYER L'ARRÊTOIR DU CHARGEUR

ATTENTION



N'utilisez que des billes BB (sans défaut). N'utilisez jamais les types de billes BB suivants: ❶ Avec angles ❷ Moitiés déplacées ❸ Usagées ou sales. Si des projectiles autres que ceux appropriés sont utilisés, la garantie ne sera plus valable. Il est recommandé d'utiliser des billes de précision de la marque UMAREX/Walther. Pour garantir le bon fonctionnement du chargeur, faites en sorte que les saletés et poussières n'entrent pas dans le chargeur.

470
ROUNDS

WEIGHT
0,2 g BB

6 mm
AIRSOFT

WEIGHT
0,25 g BB

❸
du moins 50 BBs



Appuyez sur l'arrêtoir du chargeur.



Tourner pour serrer



AJUSTAGE LA HAUSSE

FR

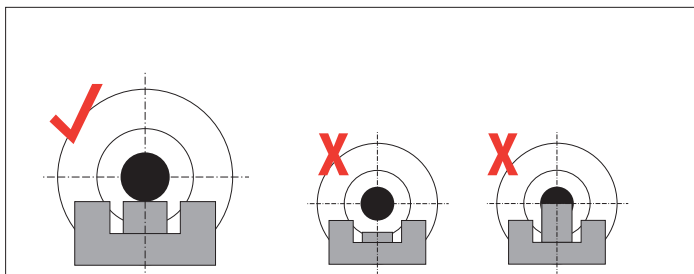
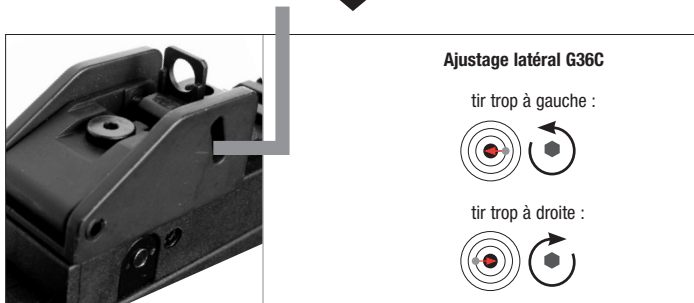
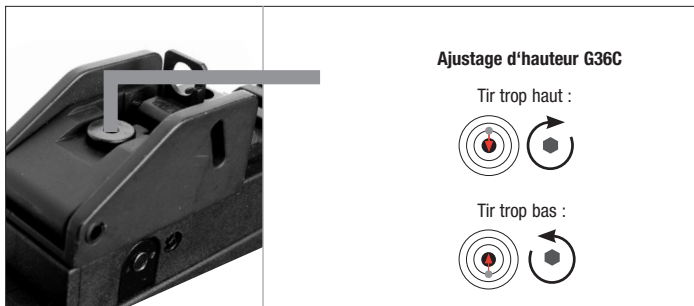

Télescope grossissement: 3,5-fois

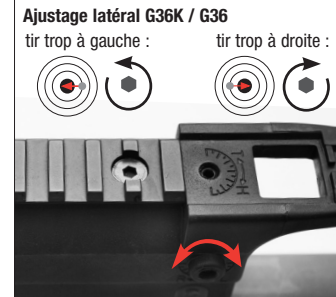

G36 Viseur point rouge

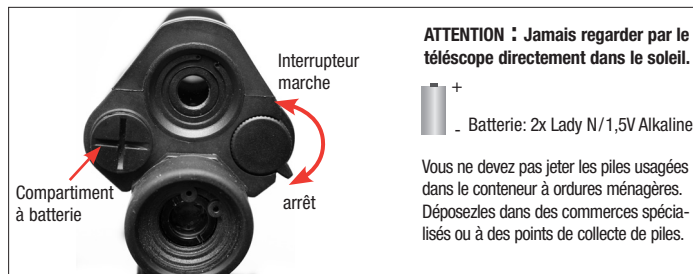
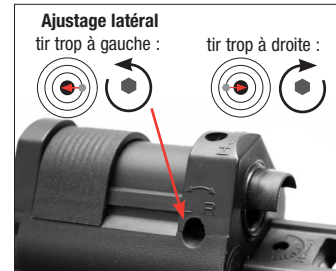
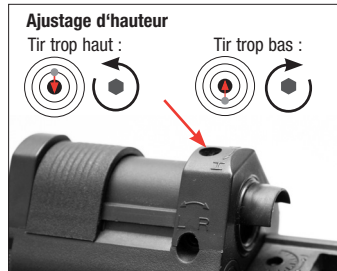

FR



ADJUSTABLE SHOOT UP

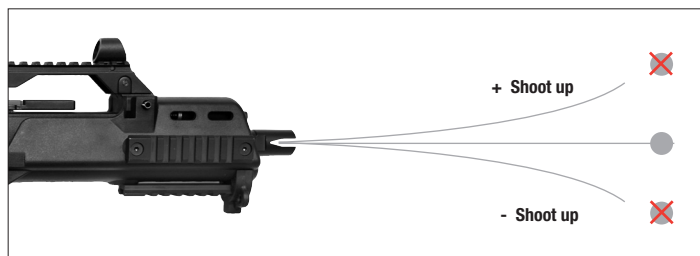

NETTOYAGE LE CANON



ATTENTION

- Reajuster le „shoot up“ à „Normal“ avant de nettoyer l'arme.
 - N'enfoncé pas la baguette de nettoyage violemment dans le canon, car elle pourrait l'endommager.
 - Ne versez jamais l'huile de silicone directement dans le canon.
- When airsoft gun is stored over a longer period without any use please make sure the battery is disconnected from the gun and push the release button before.

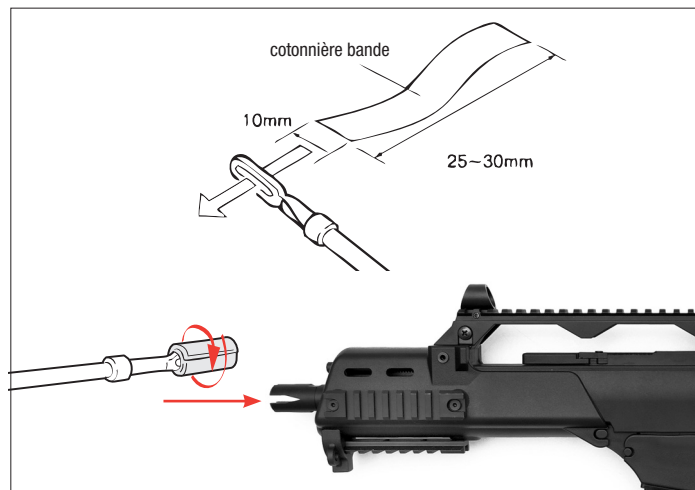

Mettez la sûreté de l'arme. Retirez le chargeur. Prenez un bâton mince d'une longueur d'env. 60 cm. Paillez un morceau d'un chiffon de coton autour du bout, mouillez le chiffon avec une petite quantité d'huile pour arme afin de nettoyer le canon.



MANEJO SEGURO DE ARMAS

ES



DESIGNACION



REGLAJE



CUIDADOS



INSTUCCIONES DE SEGURIDAD

Deberá estar familiarizado con el manejo correcto y seguro de su arma. Con respecto a las reglas básicas para disparar con seguridad, considere cada contacto con el arma como parte de su manejo.

- Trate el arma como si siempre estuviera cargada.
- Cargue siempre el arma con el seguro activado para evitar disparos involuntarios.
- Mantenga el dedo siempre fuera del gatillo y colóquelo solamente cuando vaya a disparar.
- Utilice únicamente proyectiles específicos para esta arma.
- Mantenga la boca del arma siempre en una dirección segura.
- Sólo está permitido disparar el arma en la vivienda del propietario o en las zonas de tiro autorizadas por la policía, siempre y cuando el proyectil no pueda llegar más allá del área de tiro. Para ello, tenga presente siempre la distancia máxima de peligro del proyectil.
- Nunca transporte el arma cargada. Cárguela solamente cuando tenga intención de disparar.
- Nunca apunte con el arma hacia personas o animales. Evite los disparos en los que el proyectil pueda rebotar: nunca dispare sobre superficies lisas y duras, ni al agua.
- Antes de disparar, asegúrese de que el objetivo y el entorno sean seguros.
- Antes de transportar el arma o de entregársela a otra persona compruebe siempre que está descargada.
- Asegúrese de poder controlar la dirección hacia la que apunta la boca, aún en caso de tropiezo o de caída del arma.
- Por motivos de seguridad, cuando vaya a disparar póngase siempre gafas protectoras.
- Guarde el arma siempre descargada, separada de la munición y en lugar seguro para evitar que personas no aptas (personas sin formación, niños) puedan acceder a ella.
- Entregue esta arma, junto con las instrucciones de uso, únicamente a aquellas personas que:
 - estén perfectamente familiarizadas con el manejo de esta arma
 - hayan cumplido la edad mínima correspondiente fijada por la legislación en materia de armas del país respectivo.
- Cualquier modificación o reparación del arma deberá llevarla a cabo una empresa especializada o un armero.
- Nunca deje sin vigilancia un arma cargada.
- Siempre que entregue un arma a otra persona, asegúrese de que está descargada.

GARANTIA

La empresa Umarex se responsabiliza de reparar o sustituir su arma sin coste alguno en el plazo de un año a partir de la fecha de compra, siempre que el defecto no sea responsabilidad del propio usuario. Sírvanse entregar el arma a un comerciante autorizado, descríbase el problema y adjunte el correspondiente comprobante de compra.

ES



INSTRUCCIONES DE SEGURIDAD



CUIDADOS



DESIGNACION

! ATENCIÓN

Por su propia seguridad y la de los demás, lea detenidamente las instrucciones de uso antes de disparar el arma por primera vez. Vendedores y compradores están obligados a cumplir con las normas de uso y posesión de armas de aire comprimido. Queda prohibida cualquier modificación de esta arma, ya que ello podría implicar un cambio en su clasificación legal. En caso de modificación quedaría extinguida de inmediato la garantía del fabricante.

! AVISO

No porte o muestre este arma de aire comprimido en público. Puede ser motivo de confusiones e ilegal. Miembros de las fuerzas de seguridad y la policía pueden tomarla por un arma de fuego real. No modifique el color ni los elementos identificativos para hacer que se parezca más a un arma de fuego real. Es peligroso y puede ser un delito.

REPARACIONES

Una arma que no funcione perfectamente es peligrosa. Es difícil reparar uno mismo un arma, y un ensamblaje incorrecto puede producir anomalías de funcionamiento peligrosas.

Atención: La comprobación y reparación del arma sólo pueden llevarla a cabo especialistas autorizados o un armero.

ESPECIFICACIONES

Art. Nr.	2.5746 2.5747 2.5748
Sistema:	Electric Airsoft
Calibre/Munición:	cal. 6 mm BB
Energía:	> 1,0 JOULE
Velocidad de disparo:	hasta 120 m/s con 0,20 g BB
Longitud del cañón:	540 mm 400 mm 270 mm
Longitud:	1015 mm 872 mm 720 mm
Peso:	3330 g 2985 g 2795 g
Capacidad del cargador:	470 BBs
Distancia máxima de peligro:	150 m





SEGURO



ATENCIÓN

Manipule el arma sólo cuando con el seguro activado.
Procure que la boca apunte siempre en una dirección segura.



SAFE

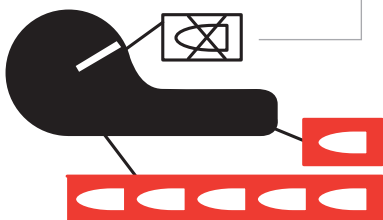

DISPARO

ES



ATENCIÓN

Durante implicar el gatillo nunca conmute el conmutador. Esto causa daños graves.

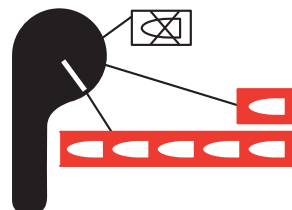
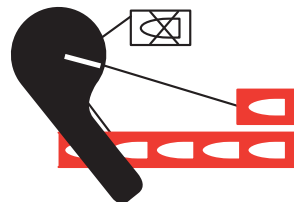



⚠️ ATENCIÓN

En caso de que la batería esté vacía, pueden producirse daños en la caja de mando que necesitarán una reparación.

No se deben descargar totalmente las baterías, ya que se podrían dañar los elementos.

La sobrecarga duradera ocasiona averías permanentes en las baterías.

Las baterías siempre deben estar descargadas antes de su carga.

En las baterías no se ofrece ninguna garantía ya que se trata de piezas consumibles.

Use solamente el tipo de batería de al menos 8,4 V.

Las pilas usadas no deben tirarse en el contenedor de basura doméstico. Deséchelas en comercios especializados o en puntos de recogida de pilas.

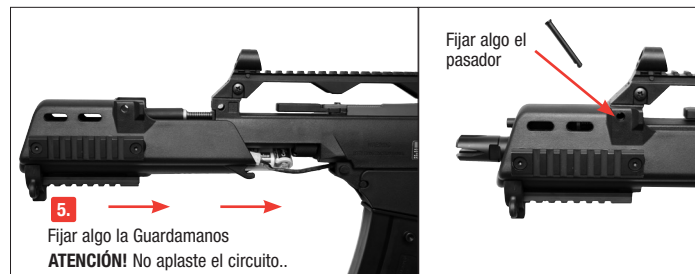
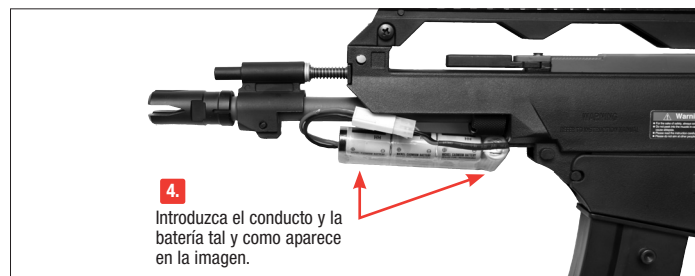
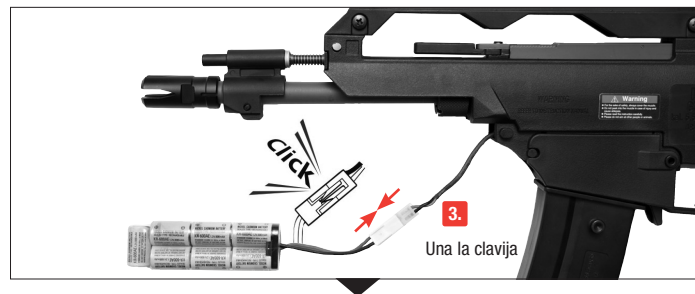
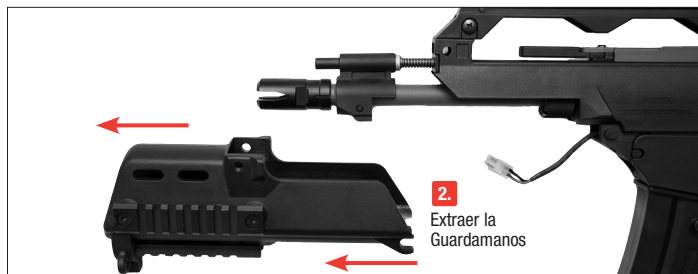
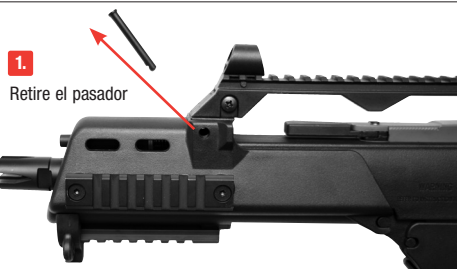



CHARGER DEL CARGADOR

ES



ATENCIÓN



Utilice únicamente bolas BB (que no presenten defectos) de calibre 6 mm. No utilice en ningún caso los siguientes tipos de bolas BB:

1 Diámetro superior a los 6 mm, 2 Con cortes, 3 Con mitades que no coinciden, 4 Usadas o sucias. Si se utilizan proyectiles distintos de los apropiados, quedará anulada la garantía. Se recomienda el uso de bolas de precisión de la marca UMAREX/Walther. Para garantizar el buen funcionamiento del magazín, evite que la suciedad o el polvo entren en el mismo.

470
ROUNDS

WEIGHT
0,2 g BB

6 mm
AIRSOFT

WEIGHT
0,25 g BB

3.
mínimo 50 BBs



Presione el soporte del cargador



5.

Click



Gire hasta que se fije



Ajuste en altura G36C

tiro demasiado alto:

tiro demasiado bajo:

Ajuste en deriva G36C

tiro demasiado hacia la derecha:

tiro demasiado hacia la izquierda:

Telescopio 3,5 x ampliación

Ajuste en altura G36K / G36

tiro demasiado alto:

tiro demasiado bajo:

Ajuste en deriva G36K / G36

tiro demasiado hacia la derecha:

tiro demasiado hacia la izquierda:

G36 Mira de punto rojo

Ajuste en altura

tiro demasiado alto:

tiro demasiado bajo:

Ajuste en deriva

tiro demasiado hacia la derecha:

tiro demasiado hacia la izquierda:

Botón de conexión

+

- Bateria: 2x Lady N/1,5V Alkaline

desconexión

Compartimiento para la batería

ATENCIÓN! Nunca mirar por el catalejo directamente en el sol.

Las pilas usadas no deben tirarse en el de basura doméstico. Deséchelas en comercios especializados o en puntos de recogida de pilas.



AJUSTE DE SHOOT UP

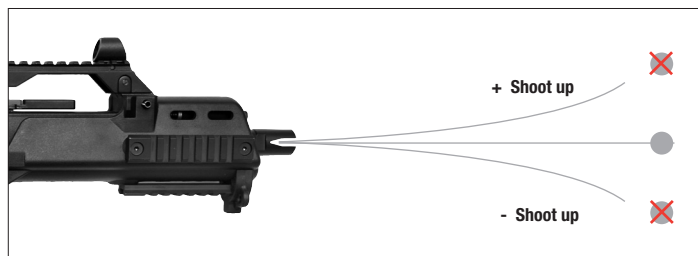

LA LIMPIEZA DE CAÑÓN

ES

ATENCIÓN

- Reajustar el „shoot up“ a „Normal“ antes limpiar el arma.
- No debe forzar la varilla de limpieza para introducirla dentro del cañón, porque podría dañar el arma.
- No vierta nunca aceite de silicona directamente dentro del cañón.
- Si quiere estocar la arma airsoft por algún tiempo se tiene que desconectar el batería y empujar el botón de distensión.

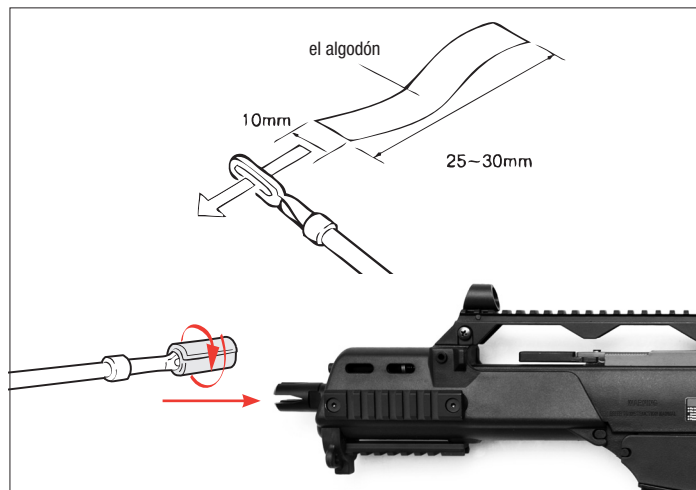

Asegure el arma. Saque el cargador. Coja una barra estrecha y larga de unos 60 cm. Enrolle un paño de algodón por el extremo, humidézcalo con un poco de aceite para armas y limpie el cañón con ayuda del mismo.

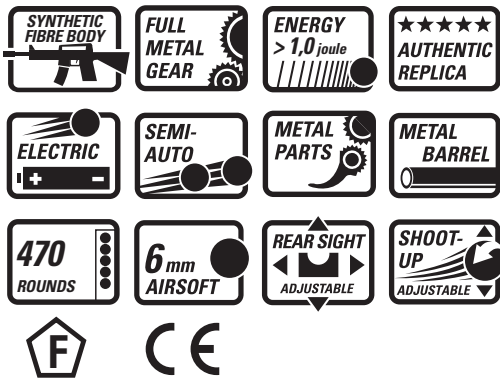

2.5748



2.5747



2.5746



UMAREX®

UMAREX Sportwaffen GmbH + Co. KG

P.O. Box 27 20
 D-59717 Arnsberg | Germany
 Phone: +49 29 32 / 638-01
 Fax: +49 29 32 / 638-222
 verkauf@umarex.de | sales@umarex.de

www.umarex.com

We reserve the right to make color and design changes and technical improvements. No responsibility is accepted for printing errors or incorrect information.

Änderungen in Farbe und Design, sowie technische Verbesserungen, Druckfehler und Irrtum vorbehalten. Alle Angaben ohne Gewähr.

Sauf modifications de la couleur et du design ainsi que des améliorations techniques, erreurs d'impression et erreur. Toutes les données sont fournies sans garantie.

Salvo modificaciones de color y de diseño así como mejoramientos técnicos, erratas y error. Todos los datos sin garantía.

© UMAREX Sportwaffen GmbH & Co. KG