

---

*User's guide for:*

***SHARPS RIFLE***



***Official Sponsor***



***ATTENTION: BEFORE REMOVING THE FIREARMS FROM  
ITS PACKAGE READ & UNDERSTAND WARNINGS AND FULL  
INSTRUCTIONS AND PRECAUTIONS IN THIS OWNER'S  
MANUAL***

### ***A historical note on the Sharps model***

*Since 1849, year in which Christian Sharps patented his first rifle, till 1882, year in which the Company ceased its activity, the Sharps rifle had a fundamental role in American History.*

*The Sharps percussion models were used in the revolutionary riots prior to the Civil War.*

*A well known episode is called “The Bloody Kansas”, when Sharps rifles hidden in Bible cases were sent in Kansas to be used in the first national revolts.*

*Sharps percussion Infantry and Cavalry models were then used by Yankee battalions during the whole war period. Above all we remember the Hiram Berdan regiment: it is thanks to his men that the term “Sharpshooters” was coined, as they were the best Yankee marksmen during the conflict.*

*The Sharps was undoubtedly one of the most popular rifles in those years, the most used both by ordinary soldiers and by officials.*

*After the Civil War many percussion Sharps rifles were converted into breech loading rifles with metal cartridges.*

*The post-war years were golden years for the Sharps Company; production increased strongly, and at the same time the activity of converting percussion rifles into rifles with classic loading grew.*

*The most famous Sharps among all the models that the company produced was certainly the “Sporting 1874 model, also called the “Old Reliable Buffalo Rifle”.*

*Many famous names in the America of that period are bound to the name of Sharps. Men like Billy Dixon, “Buffalo Bill” Cody, “Bat” Matterson and many others used the “great single shot rifle” in hunting bisons, at the time when this animal was still roaming with immense herds on American plains.*

*The large variety of calibers – from an easy cal. 40 to a more massive cal. 50 – also contributed to Sharps’ being the most important and most popular rifle during those years.*

*The Sharps rifles were famous for their feature of being able to shoot their big black powder bullets huge distances with extreme accuracy.*

*For several years Armi Sport has been producing a faithful replica of all parts of this rifle. In particular, metallic parts are machined from solid steel blocks (instead of being casted), and this allows an exceptional working reliability and a perfect interchangeability; a feature which is really difficult to find in artisan crafted firearms.*

# INDEX

<i>Warnings</i>	4
<i>Sharps models</i>	7
<i>Rifle parts nomenclature</i>	9
<i>Instruction of use - Precautions</i>	10
<i>Instruction of use - Loading a percussion Sharps</i>	11
<i>Instruction of use - Loading a Sharps cartridge model</i>	14
<i>Double set trigger (“Stecher” system)</i>	15
<i>Extraction-unloading</i>	16
<i>Markings</i>	16
<i>Ordinary cleaning</i>	17
<i>Ordinary and extraordinary maintenance</i>	18
<i>Rear sight and front sight adjustment</i>	18
<i>A note about historical design</i>	19
<i>Exploded views and components</i>	20
<i>Warranty</i>	43

# WARNINGS

*Armi Sport is not responsible for damage to objects caused by misuse of the gun or for injuries to person or animals, or in case of death, caused voluntarily or involuntarily by the gun user.*

*Armi Sport is not responsible for injuries caused by poor maintenance, misuse of the gun, unauthorized or improper modifications.*

*Armi Sport declines responsibility for the indirect consequences of any injuries and / or death of persons or animals, damage to objects caused by use of the gun or by primer explosion, by bullet’s ricochet, or unsafe loading practices and / or procedure.*

*The gun you own is an accurate 19th century replica. Consequently its safety devices are limited to the technological knowledge of the period. Therefore the risks in using a gun like this are higher compared to a modern design gun.*

*The complete and full knowledge of your firearm may help you to avoid serious injuries due to lack of safety devices.*

*Read the entire manual and learn the proper use of the gun without live ammunition. It is important that you understand the proper use of this product. The life of the people close to you may depend on your safety.*

*If the manual is not clear, please contact the dealer where you bought the gun or call the distributor or the manufacturer by using the contact information provided within this manual.*

*All our guns are tested in the Armi Sport facility. To guarantee the gun is safe, it is sent to the National Proof House of Gardone Val Trompia – BRESCIA – ITALY - for proof testing.*

*The Proof House tests the firearm with heavy loads then checks the barrel, chamber and headspace to make certain the firearm is safe for use with standard factory ammunition.*

*The National Proof House will put their markings on the gun, according to the Italian law, certifying the gun is qualified and can be sold.*

***THE COURT OF BRESCIA - ITALY, WILL SETTLE ALL DISPUTES.***

1. Read the instructions carefully before use.
2. Be aware that you are handling a firearm; therefore your knowledge and behaviour may affect your life and those of the people close to you.
3. Reading the manual and a careful examination of the gun are fundamental to avoid any kind of problem.
4. Guns and ammunitions must be kept in different places
5. **ALWAYS** keep guns and ammunitions out of reach of children.
6. Store the gun in a clean dry and airy place after use to avoid rust in mechanical parts that may cause serious problems in functioning after a period of inactivity.
7. After use it is always recommended to clean, oil and lubricate the gun with good quality oil.
8. The gun must **ALWAYS** be stored unloaded, **ALWAYS** check that the chamber is empty.
9. Being this firearm is a replica of original design, there is no modern safety. Pay great attention during transportation and use. Mechanical safety devices can fail. Developing intelligent, good safety habits is the best way to prevent accidents.
10. The only safety is the hammer half cock, read chapter on firearms use. REMEMBER: No mechanical safety device is infallible.
11. **ALWAYS** keep the gun unloaded when transporting it from home to the shooting areas. Carefully check that cartridge chamber is empty.
12. Keep away from open flame or heating sources.
13. Use only factory ammunition with specific loads intended for this firearm.
14. When you walk around with the gun in a shooting area, ALWAYS keep the muzzle pointed in a safe direction.
15. Never rest your finger on the trigger until the very moment you wish to shoot.
16. Never lean the weapon loaded and with a closed breech block, it could fall and cause injury and death.
17. Never shoot against a solid surface or in a pool of water, the projectiles could ricochet and shoot toward any direction.
18. Before shooting ALWAYS check to ensure that the barrel is free of obstructions.

19. After use, clean and lubricate the inside of the barrel with appropriate oil. Avoid grease or oil build up that can cause excessive pressure and result in serious personal injuries. Before using the gun again, inspect the barrel and chamber to make certain that there are no obstructions in the bore. Remove any oil residue with rod and dry patch before shooting.
20. Accumulation of rust in the barrel can cause excessive pressures resulting in serious injury and may cause the explosion of the barrel. A rusted, pitted or eroded barrel should be replaced.
21. Always wear shooting glasses when shooting to protect your eyes.
22. Use hearing protection to prevent hearing loss from repeated exposure to gunfire.
23. **NEVER** modify any parts of your gun. Any alteration may cause serious personal injury and voids the warranty.
24. Only a qualified gunsmith may service the gun for repair or serious maintenance.
25. Wash hands thoroughly after shooting and handling firearms to remove any unwanted residues.
26. Use exclusively factory loaded ammunition of the caliber specified on the firearm barrel. Use of different calibers may cause serious personal injuries to you and to people close to you.
27. In case of misfire, manually extract the cartridge from the chamber.
28. Do not attempt to re-use unexploded ammunitions.
29. Armi Sport/ Chiappa Firearms declines any responsibility for misuse of the firearm.
30. In case of alteration of the firearm, Armi Sport/ Chiappa Firearms declines any civil and penal responsibility and will not refund any damage.
31. The user is responsible for injuries or damages caused to him or to other persons.
32. Do not use alcohol or drugs before or during shooting session and while handling guns.
33. NEVER run with a loaded gun, don't cross any obstacle (fences or water courses, etc.) without having your firearm unloaded and in safety position.
34. Keep all bystanders behind you, standing beside a shooter is not a safe position.
35. Complete knowledge of your firearm can make the difference.

*Armi Sport is proud to introduce the range of  
our Sharps*

Item Code	Description	Trigger	Barrel length	Caliber	Exploded view – See page
<b>Percussion models</b>					
910.010	1863 SHARPS SPORTING	Double	30"	54	Pag.20-21
910.011	1863 SHARPS SPORTING	Single	30"	54	Pag.20-21
910.012	1863 SHARPS SPORTING	Double	32"	54	Pag.20-21
910.013	1863 SHARPS SPORTING	Single	32"	54	Pag.20-21
910.021	1863 SHARPS SPORTING	Double	30"	451	Pag.20-21
910.029	1863 SHARPS SPORTING	Single	30"	451	Pag.20-21
910.022	1863 SHARPS SPORTING chequered	Double	32"	451	Pag.20-21
910.024	1863 SHARPS SPORTING chequered	Double	32"	54	Pag.20-21
910.030	1863 SHARPS SPORTING – pewter tip	Double	32"	54	Pag.20-21
910.035	1863 SHARPS SPORTING – pewter tip	Single	32"	451	Pag.20-21
910.036	1863 SHARPS SPORTING – pewter tip	Double	32"	451	Pag.20-21
910.019	1863 SHARPS SPORTING– engraved - chequered	Double	32"	451	Pag.20-21
910.020	1863 SHARPS SPORTING – engraved - chequered	Double	32"	54	Pag.20-21
910.015	1859 SHARPS CAVALRY	Single	22"	54	Pag.22-23
910.014	1859 SHARPS CAVALRY - patchbox	Single	22"	54	Pag.22-23
910.016	1859 SHARPS INFANTRY patchbox	Single	30"	54	Pag.24-25
910.017	1859 SHARPS BERDAN patchbox	Single	30"	54	Pag.24-25
910.027	1859 SHARPS BERDAN patchbox	Double	30"	.451	Pag.24-25
910.028	1859 SHARPS BERDAN patchbox	Double	30"	.54	Pag.24-25
<b>Metallic cartridge models</b>					
920.000	1874 SHARPS SPORTING	Single	30"	45/70	Pag.26-27
920.001	1874 SHARPS SPORTING	Double	32"	45/70	Pag.26-27
920.008	1874 SHARPS SPORTING	Double	30"	45/70	Pag.26-27
920.009	1874 SHARPS SPORTING	Single	32"	45/70	Pag.26-27
920.010	1874 SHARPS SPORTING	Double	34"	45/70	Pag.26-27
920.156	1874 SHARPS SPORTING	Double	34"	45/70	Pag.26-27
920.002	1874 SHARPS SPORTING – pewter tip	Double	32"	45/70	Pag.26-27
920.003	1874 SHARPS SPORTING – pewter tip	Double	32"	40/65	Pag.26-27
920.005	1874 SHARPS SPORTING - pewter tip	Double	32"	45/90	Pag.26-27
920.006	1874 SHARPS SPORTING - pewter tip	Double	32"	45/120	Pag.26-27
920.011	1874 SHARPS SPORTING – pewter tip	Double	34"	45/70	Pag.26-27
920.019	1874 SHARPS SPORTING – pewter tip -	Double	34"	45/90	Pag.26-27
920.020	1874 SHARPS SPORTING – pewter tip -	Double	34"	45/120	Pag.26-27
920.024	1874 SHARPS SPORTING –patchbox	Double	32"	45/70	Pag.26-27
920.037	1874 SHARPS SPORTING –chequered	Double	32"	45/70	Pag.26-27
920.049	1874 SHARPS SPORTING – patchbox chequered	Double	34"	45/120	Pag.26-27
920.050	1874 SHARPS SPORTING - patchbox chequered	Double	34"	45/70	Pag.26-27
920.025	1874 SHARPS SPORTING patchbox- pewter tip - chequered	Double	32"	45/70	Pag.26-27
920.031	1874 SHARPS SPORTING patchbox- pewter tip – chequered	Double	32"	45/120	Pag.26-27

Item Code	Description	Trigger	Barrel length	Caliber	Exploded view - See page
920.046	1874 SHARPS SPORTING patchbox- pewter tip – chequered	Double	32"	45/120	Pag.26-27
920.059	1874 SHARPS SPORTING	Double	34"	45/120	Pag.26-27
920.007	1874 SHARPS SPORTING white finish – patchbox	Double	32"	45/70	Pag.26-27
920.004	1874 SHARPS SPORTING white finish- patchbox- pewter tip – chequered	Double	32"	45/70	Pag.26-27
920.012	1874 SHARPS SPORTING – pewter tip hand engraved – chequered	Double	32"	45/70	Pag.26-27
920.013	1874 SHARPS SPORTING – pewter tip - hand engraved with gold inletting– chequered extra grade wood	Double	32"	45/70	Pag.26-27
920.014	1874 SHARPS SPORTING – pewter tip -hand engraved with gold inletting – chequered extra grade wood	Double	34"	45/120	Pag.26-27
920.015	1874 SHARPS INFANTRY – patchbox	Single	30"	45/70	Pag.34-35
920.016	1874 SHARPS BERDAN -patchbox	Double	30"	45/70	Pag.34-35
920.110	SHARPS BILLY DIXON – pewter tip- chequered	Double	32"	45/70	Pag.26-27
920.112	SHARPS BILLY DIXON – pewter tip – chequered	Double	32"	45/90	Pag.26-27
920.114	SHARPS BILLY DIXON – pewter tip	Double	32"	45/110	Pag.26-27
920.115	SHARPS BILLY DIXON – pewter tip	Double	32"	50/90	Pag.26-27
920.028	SHARPS QUIGLEY –patchbox – heavy barrel	Double	34"	45/70	Pag.28-29
920.029	SHARPS QUIGLEY - patchbox – heavy barrel	Double	34"	45/90	Pag.28-29
920.030	SHARPS QUIGLEY - patchbox – heavy barrel	Double	34"	45/120	Pag.28-29
920.044	SHARPS QUIGLEY - patchbox – heavy barrel	Double	34"	50/90	Pag.28-29
920.045	SHARPS QUIGLEY - patchbox – heavy barrel	Double	34"	45/110	Pag.28-29
920.096	SHARPS QUIGLEY - patchbox – heavy barrel	Double	34"	38/55Win	Pag.28-29
920.164	SHARPS CREEDMOOR	Double	34"	45/70	Pag.30-31
920.017	1874 SHARPS CAVALRY	Single	22"	45/70	Pag.32-33
920.055	1874 SHARPS CAVALRY	Single	22"	50/70	Pag.32-33
920.047	1874 SHARPS TEXAS CAVARLY	Single	22"	45/70	Pag.36-37
920.048	1874 SHARPS TEXAS CAVARLY	Single	22"	50/70	Pag.36-37
	<b>Mini Sharps</b>				
920.187	MINI SHARPS	Double	24"	22WinMag	Pag.38-39
920.188	MINI SHARPS	Double	24"	22LR	Pag.38-39
920.189	MINI SHARPS	Double	26"	45 LC	Pag.38-39
920.190	MINI SHARPS	Double	26"	44/40 Win	Pag.38-39
920.191	MINI SHARPS	Double	26"	38/55 Win	Pag.38-39
920.192	MINI SHARPS	Double	26"	22 Hornet	Pag.38-39
920.194	MINI SHARPS	Double	26"	30/30 Win	Pag.38-39
920.196	MINI SHARPS	Double	24"	17 HMR	Pag.38-39
920.197	MINI SHARPS	Double	26"	218 BEE	Pag.38-39
920.203	MINI SHARPS	Double	26"	.357 MAG	Pag.38-39
920.208	MINI SHARPS	Double	24"	22 LR	Pag.38-39

*Each firearm is duly submitted to strong testing, to grant the highest security of the product, by the Italian Proof House in Gardone Valrompia.*

*On request we may add high quality and precious hand engravings in each firearm.*

Sharps rifle:  
essential parts  
nomenclature

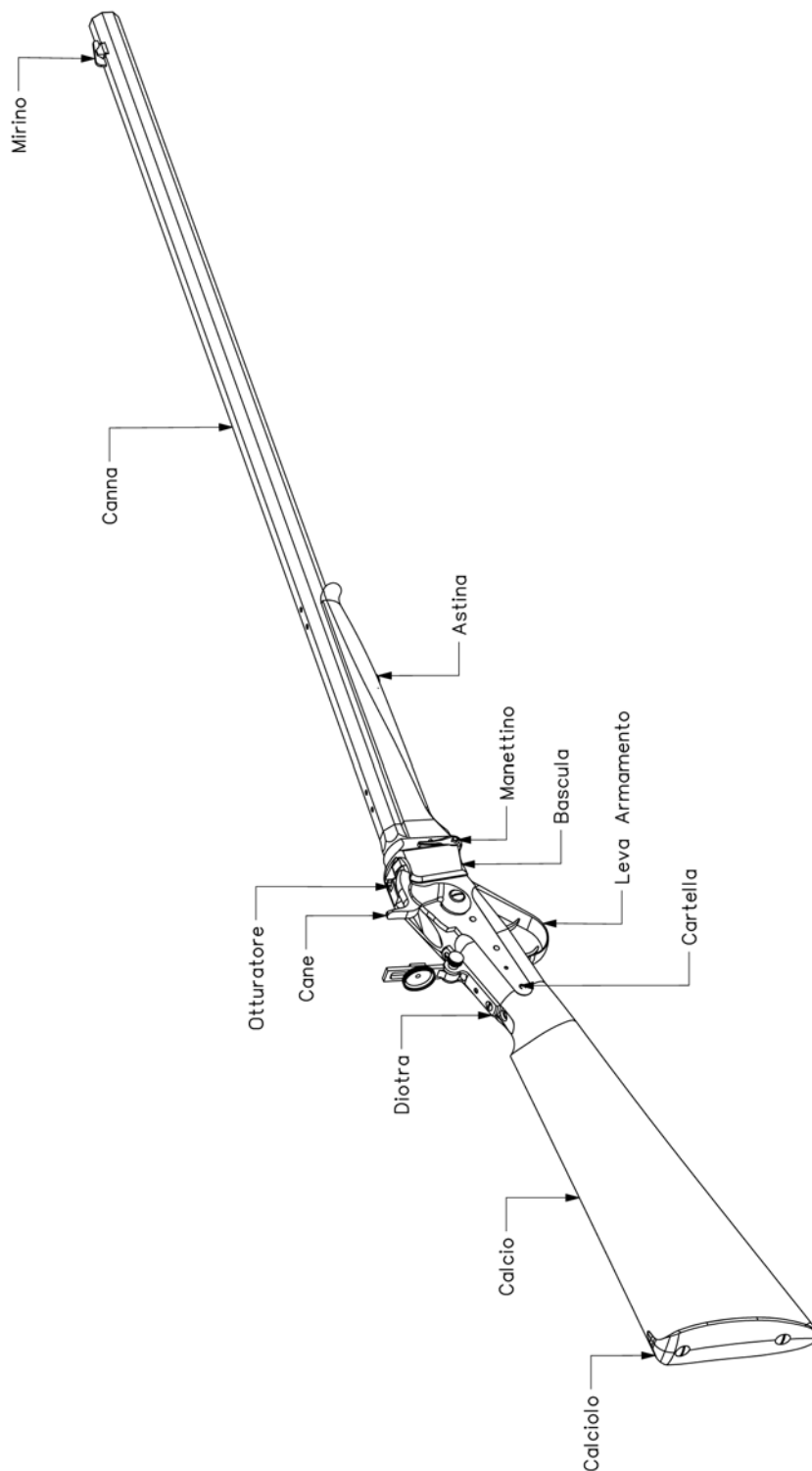

## *Instructions for use*

### **Precaution:**

- Before handling the firearms, be sure it's unloaded and pointed in a safe direction.
- Before shooting, ALWAYS check to ensure that the barrel is free of obstructions .
- Remove any oil or grease residue with rod and dry patches changing them till they come out perfectly clean and dry.
- Use hearing protection to prevent hearing loss from repeated exposure to gunfire.
- In case of misfire, keep the gun on the shooting line for a few minutes, it could be a delayed shot.
- NEVER dry fire the gun, you may damage the shooting mechanism.
- During loading, pay the utmost attention at what you're doing - pouring a double charge or twice a projectile could cause the explosion of the barrel, and severe injuries to you and the people close to you.
- Double trigger regulation: if your rifle has a double trigger, now it's time to adjust it. Be sure the gun is unloaded and put the hammer in half cock position. Pull the rear trigger, then pointing the gun in a safe direction pull the front trigger to test the trigger pull. In case the pull is too hard, screw in the "regulating screw" by 1/6 of turn and try again. Repeat the operation till the trigger pull is correct for your sensitivity. **THE TRIGGER PULL MUST NEVER BE TOO LIGHT**

## ***Loading a percussion Sharps:***

*Percussion Sharps was one of the most popular firearms of the ante-cartridge period.*

*One of the reason for its great popularity undoubtedly was the fact that this model had a substantial reduction of gas escape after shooting.*

*Christian Sharps invented an innovative system, a floating chamber inserted into the cartridge chamber. This floating chamber moved backward during explosion, due to the gas pressure created by the shot, while the breech block was sealed, not allowing gases to escape from the breech.*

*Some minor gas escapes are of course acceptable (the improvement compared to a classic muzzle loading gun was really consistent).*

*There are three different systems to load a percussion Sharps.*

*The first one uses lead bullets and black powder (Pict. 1), the second paper cartridges (Pict. 2) while the third one uses specific reloadable brass shells (Pict. 3).*

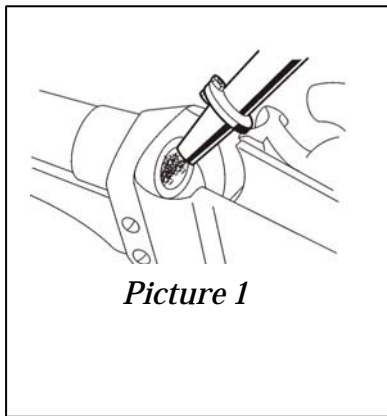

*Picture 1*

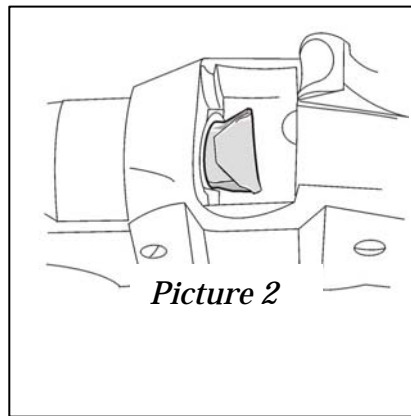

*Picture 2*

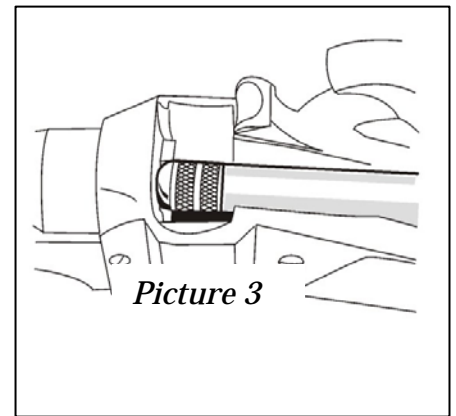

*Picture 3*

### *First system:*

- *Before you start loading, check to ensure that the barrel is free of obstructions .*
- *Remove any oil or grease residues inside the barrel with rod and patch.*
- *It is always useful after cleaning the barrel to point it in a safe direction and shoot with the primer only one or two shots to verify the nipple is not obstructed and to dry the barrel from oil residues.*
- *Put the hammer in half cock*
- *Open the breech block*
- *Insert a lead bullet in the cartridge chamber.*
- *Push it with a rod till it reaches the beginning of the rifling and it is stabilized in the cartridge chamber.*
- *Point the gun in a safe direction.*
- *Pour a measure of powder in the chamber.*
- *The maximum powder load poured into the chamber should not exceed 60 grains for .45 caliber and 80 grains for .54 caliber (the grains indicated are referred to Swiss black powder nr.3).*
- *Be sure that the chamber is completely filled up with powder so that there are no empty spaces between powder and bullet.*
- *The black powder capacity indicated may vary based on the bullet dimension/shape.*

- *During this operation pay attention you don't keep your head or part of your body over the muzzle of the barrel, a sudden burst may seriously injure you.*
- *In order to facilitate the introduction of the powder you should employ the apposite brass funnel, which allows the powder to slide perfectly down the bottom.*
- *Once you have loaded the powder, beat your hand on the side of the weapon, near the lock.*
- *It is fundamental that no air is left between powder and bullet.*
- *Close the breech block.*
- *Clean the rifle from powder residual, exceeding black powder around nipple or breech block may be dangerous.*
- *Possible lack of accumulated powder is a feature of percussion Sharps; this characteristic was well known during the Civil War – in fact, the loading operations were carried out with great carefulness.*
- *Now, direct the muzzle in the shooting direction and place the cap on the nipple.*
- *Cock the hammer and shoot.*
- *After every shot, before you start a new loading, wait a while so possible powder residual in the barrel can extinguish.*
- *Always pay attention when introducing the powder inside the weapon; always keep the mouth of the muzzle far from your body.*

Second system:

*Before proceeding with the loading instructions it's good to explain how to properly prepare a paper cartridge.*

- *Use linen paper*
- *Such paper must be dipped in a nitre solution*
- *The nitre solution is made adding potassium nitrate to water at normal room temperature*
- *Paper must then be cut and dried.*
- *To help you with this work, we have prepared a set which includes all parts necessary to prepare in the correct way and by yourself paper cartridges for your percussion Sharps. This set includes ready-cut nitre paper sheets for .45 or .54 caliber, a dummy to roll the paper on, glue to close the shell and a funnel to fill the paper shell with black powder.*
- *Once the paper is dry, roll it on a pin of the correct diameter, based on the bullet caliber you wish to prepare*
- *Insert a lead bullet (item 970.122 for .451 cal. and item 970.128 for .54 cal.)*
- *Fix the bullet to the paper with glue or better, tie a silk wire around the bullet so that it goes into the lead grooves.*
- *Now fill in the shell with black powder.*
- *The maximum load of powder should not exceed 60 grains for .45 caliber and 80 grains for .54 caliber.*
- *Now bend the open side of the paper, glue it or close with nylon or cotton wire.*
- *It's fundamental that no air is left between bullet and powder.*

*Let's now proceed with the loading instructions; please pay great attention and guard your safety.*

- *Put the hammer in half cock.*
- *Open the breech block using the lever.*
- *Insert the prepared cartridge into the cartridge chamber.*

- *Close the breech block.*
- *Closing the breech block will cut the end of the paper cartridge, thus allowing the black powder to flow into the cartridge chamber.*
- *Clean the rifle from any residues of black powder.*
- *Your Sharps is now ready to be used.*
- *Now direct the gun in the shooting direction and place the cap over the nipple.*
- *Fully cock the hammer and shoot.*
- *Nitre paper has the characteristic to burn completely once black powder burns, so you will not have residues in the chamber.*
- *IT IS FUNDAMENTAL TO wipe cartridge chamber between one shot and the other. Eventual sparks could cause next shot explosion while you are still loading.*

The third system is using brass shells (item ref. 970.012-970.119). Shells work in the same way as paper cartridges, but with the advantage they can be re-used.

- *Fill in the brass shell with black powder.*
- *We suggest a quantity of black powder of 47÷50 grs for .45 caliber and 52÷55 grs for .54 caliber. Such loads are referred to Swiss powder no.2; the quantity may vary according to the grain of black or equivalent powder (Pyrodex) used and to the style of the bullet..*
- *In order to avoid powder leaking from the injection hole, place on the bottom of the shell a little piece of thin paper.*
- *Insert a lubricated bullet and make sure it is correctly seated on the black powder.*
- *Powder must be slightly pressed for about 1÷2 mm; excessive pressure could cause a loss of power.*
- *It's fundamental not to leave any gap between black powder and bullet.*
- *Together with the shells you will find a brass base, which must be inserted inside the breechblock to obtain a tight closing and a lower gas escape.*
  
- *Place the hammer in half cock.*
- *Open the block.*
- *Insert the cartridge into the chamber.*
- *Pierce the paper placed on the bottom of the shell to allow the sparks to light the powder.*
- *Close the breech block.*
- *Remove any powder residues from the rifle.*
- *Your Sharps is now ready to shoot.*
- *Now direct your rifle in shooting direction and place cap on the nipple.*
- *Fully cock the hammer and shoot.*

### ***Loading a Sharps cartridge model:***

*Cartridge Sharps means a rifle using metal cartridges with primer commonly on sale.*

*That being stated, it's good to remind that such guns were produced as copies of percussion Sharps that we have previously described.*

*These rifles were copies of those designed for use with black powder or Pyrodex or other shooting powders approved to substitute black powder.*

*Cartridges with different powders may be employed only if they have bursting pressures absolutely equal to that of black powder.*

***The guarantee is not valid in case commercial cartridge cases are used, which have been self-reloaded with powders that are not permitted.***

*Loading instruction:*

- *Before loading check the barrel for possible obstructions.*
- *Clean the barrel with a cotton patch to remove any oil or grease residues.*
- *Aim the gun in a safe direction.*
- *Place the hammer in half cock (safety position) and open the lever; if hammer would be fully down, the firing pin would protrude out of the block and moving the lever and consequently the block, you could easily brake or bend it; furthermore if hammer would be in full cock, once cartridge is inserted in the chamber and the block closed, you would risk to accidentally shoot the ammo.*
- *Insert cartridge of the proper caliber.*
- *The cartridge has to sleeve easily inside the chamber.*
- *DO NOT FORCE THE CARTRIDGE DURING CHAMBERING.*
- *DO NOT LOAD DIFFERENT CALIBER AMMUNITIONS THAN WHAT MARKED ON THE BARREL.*
- *If cartridge doesn't enter easily in the chamber, remove it and check the cartridge chamber is not obstructed or ruined.*
- *Check the cartridge is of correct caliber and dimension*
- *Do not use ammunition with protruding primer, you risk to accidentally shoot the ammo when closing the breech block.*
- *With cartridge chambered and the gun aiming in a safe direction, close the breech block.*
- *Now aim at your target and fully cock the hammer and shoot.*

*As to reloaded cartridges, we wish to point out that the Sharps rifle has been designed and manufactured for use with black powder and similar (Pyrodex) only. As far as the loading is concerned, we suggest to use a loading manual from specialized companies (for instance RCBS, Lyman, etc)*

**Double set trigger:**

Some of our Sharps are supplied with double set trigger, which works as explained here below (Fig.3).

- *Front trigger (62): it's the shooting one, it can fire both in double set trigger mode or in normal mode.*
- *Rear trigger (66): it is under spring tension (65).*
- *Pulling the rear trigger loads the system and puts in balance the two triggers springs (65-60).*
- *Pulling the front trigger brakes such balance: the rear trigger lifts, pushed from its spring, and releases the sear to fire.*

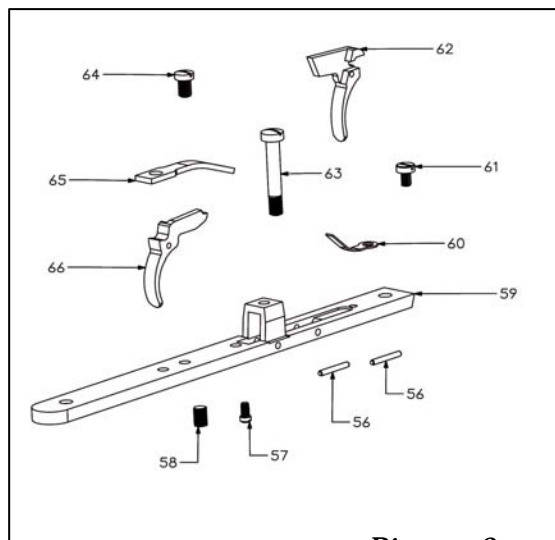

Picture 3

**Warning:  
trigger pull  
must never be  
too light**

- *If once you have pulled the front trigger, the hammer is not released, adjust the rear trigger spring screw (58); the power of the hit could not be enough to release the hammer. Unscrewing slightly that screw you the power of the rear trigger will be improved. Unscrew it till the power is enough to release the hammer.*
- *It is normal that after some time the spring becomes a little weaker. In such case just turn anticlockwise the screw by a quarter of turn (58)*
- *To obtain sensitive pulls it's necessary to adjust the trigger screw (57); turning the screw anticlockwise the trigger pull becomes more sensitive (reaching a point when the rear trigger cannot catch the front trigger), turning the screw clockwise you will obtain an harder trigger pull.*
- *To adjust the double set trigger follow the instructions below*
  - *Unscrew regulating trigger screw completely (57)*
  - *Pull rear trigger (66)*
  - *Slowly screw in the regulating trigger screw (57) till the front trigger will be released*
  - *Now turn the screw clockwise for a complete turn*
  - *Now a light pressure on front trigger is enough to release the shot.*
- *The rifle can shoot even without the double set trigger: once the gun is loaded, just pull the front trigger. The trigger pull in this case will be considerably higher compared to the trigger pull using double set trigger system.*

- **WARNING:** all adjustments of double set trigger **MUST BE DONE** with the gun unloaded. NEVER load the gun with double set trigger armed and cocked hammer.

### **Extraction:**

- Immediately after cartridge explosion, place the hammer in half cock and open the breech block.
- When the block is falling, the extractor placed on the block will be rotating and extract the shell from cartridge chamber.
- Should the extraction not be fully accomplished, especially by longer shells, it is necessary to complete the operation manually.
- Attention: if cartridge chamber or receiver are not clean enough, it could happen that the extractor gets stuck once the shell is extracted (block down, lever open). This will not allow the lever to move and breech block to lift. In this case, move the extractor manually to disengage it. Remember to clean the gun carefully.

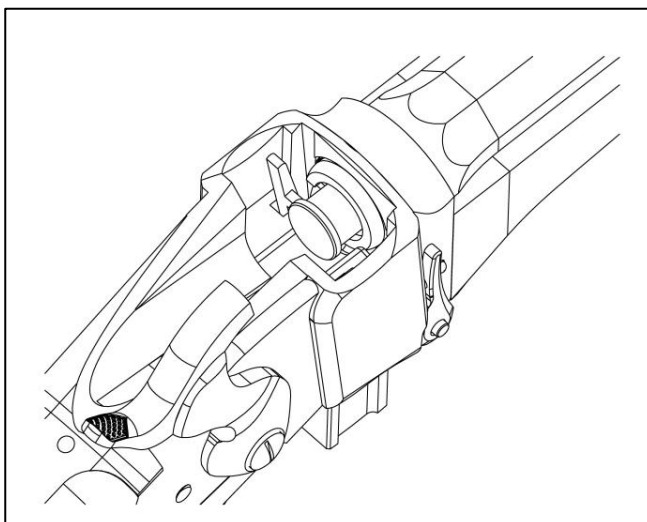

### **Identifying markings:**

Every gun we produce has a serial number that is marked on the barrel. Close to the serial number you will also find National Proof House markings. On the barrel there is also marked our company name, gun caliber, Made in Italy and - when appropriate - Black Powder Only.

**These markings must not be removed from the firearm for any reason.**

### **Ordinary cleaning:**

*Cleaning of percussion and cartridge models is very similar. Follow the steps listed below:*

- *Place the hammer in half-cock position, so that the firing pin is not protruding out of the breech block and you don't risk to spoil it or the breechblock.*
- *Open the lever and place it in a position where the lever spring is not working*
- *Turn the lever pin clockwise and extract it from its seat.*

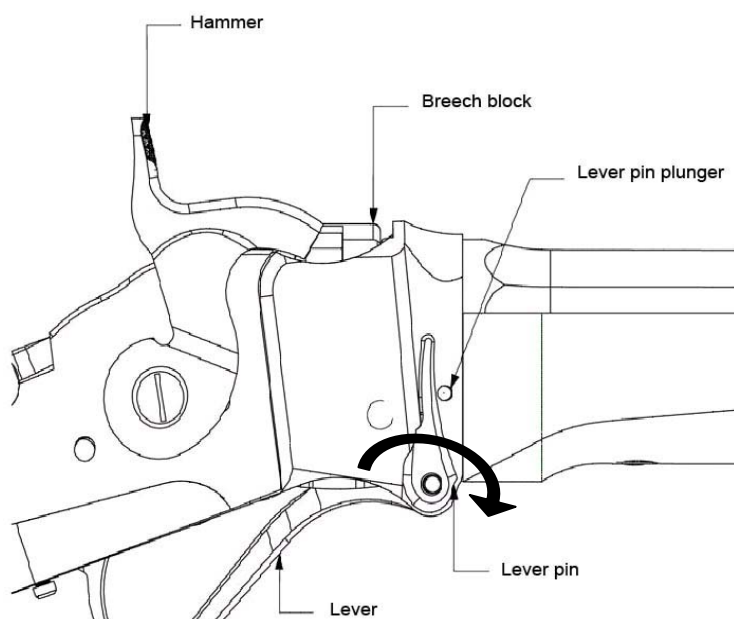

- *If lever pin is too hard to extract, remove the forend screws and unscrew the lever spring screw, in this way it should be easier to remove the lever pin.*
- *Now the entire breech block group will be free to fall out of the receiver.*
- *Clean with a solvent the inside of the receiver, barrel and block.*
- *Slightly oil and reassemble.*
- *When you reassemble the parts, place the extractor into its seat in the block, place the rifle with muzzle up and sleeve the block into the receiver.*
- *Move simultaneously block and extractor till you will see at the side of receiver the mounting holes aligned.*
- *Lock the parts with the lever pin.*
- *When shooting with black powder or Pyrodex the barrel should be cleaned every two shots to keep good accuracy and easy loading.*
- *Often black powder residues are left at the beginning of the cartridge chamber; clean with a slightly wet brush.*
- *Occasionally you can proceed with deeper cleaning, for example disassembling the firing pin, or lock and trigger plate. Such steps are not so easy and you must pay great attention to avoid damaging the gun.*
- *In case you own a percussion rifle you have to clean also floating chamber seat. You can remove the block first and then remove the floating chamber (in case the floating chamber is stuck into the barrel, you have to use the proper extractor tool item 970.011).*

## **Ordinary and extraordinary maintenance**

- *Before any kind of maintenance verify that the gun is unloaded.*
- *Ordinary maintenance means all the steps the owner should follow to keep the gun in good service before and after shooting.*
- *Extraordinary maintenance implies the change of broken or worn parts and disassembling the gun. In this case only authorized personnel may service the gun for maintenance or repair.*
- *Also a revision, after a long period of storage, has to be considered an extraordinary maintenance. This is why it is mandatory, after use, to clean properly the inside of the barrel and to oil it with a specific lubricant for weapons.*
- *The gun dealer where you bought your weapon may suggest the best lubricant to use.*
- *Avoid excessive residual oil.*
- *Check that the mechanism of the weapon is smooth; in case you notice the mechanism of the weapon is getting hard, or some essential parts start to rust, you should bring your weapon to competent, authorized personnel.*
- *Don't use pure silicone or lanoline.*
- *After long periods of inactivity of your rifle, it's advisable to completely disassemble and inspect it or give it to an authorized gunsmith for inspection.*
- *Should it be necessary to replace any worn or damaged parts, you will find below an exploded view with a list of the part number for all components.*
- *If you need to order any parts, it is necessary to indicate the purchase date, the serial number, the exact model and the caliber of your gun and the item ref. of the part you need.*
- *If you have any doubt about a problem with your gun, DON'T USE IT, have it inspected by an authorized dealer or gunsmith.*
- *Improper use or actions may cause serious injury and/or death to yourself and/or any bystanders during the firearm's use. Always use your rifle with care and respect to avoid any incident or event that may change your life and that of others.*

## **Rear sight and front sight adjustment:**

*Most of our weapons are replicas of original military weapons, which were not equipped with accurate sight systems. It is therefore necessary to carry out a few operations in order to regulate the sight devices to their maximum performance.*

**Front and rear sight modification should be the last option**

*When you start using one of our weapons, you should make a few shooting tests in order to establish what is the perfect ball size and the powder quantity that grant the best results. In case you have dove tail shape sights, it is possible to correct the point of impact by moving the front and or rear sights to the right or to the left. If you have fixed sights, alignment can be reached shaping or filing the front sight and/or the rear sight.*

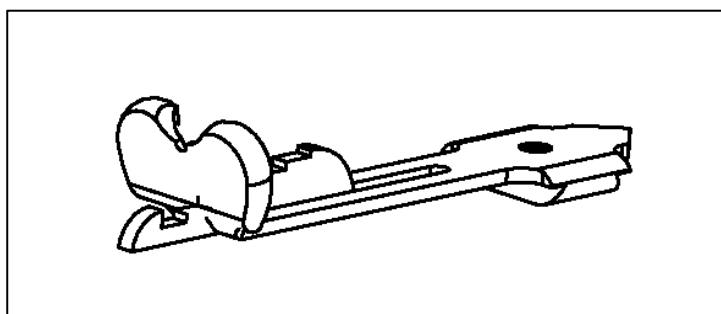

### **A NOTE ABOUT HISTORICAL FIREARM DESIGNS**

Armi Sport proudly manufactures finely crafted replica firearms reproducing famous historical weapons. These firearms are manufactured using leading edge machinery and high quality modern materials. They are faithful reproductions of firearms originally designed in the nineteenth century; therefore, if you choose to own or use historical firearms you should be aware that, along the one hundred or more years past, there have been significant advances in firearms design and safety. Armi Sport manufactures these guns not as state of the art firearms, but as historically significant firearms for the collector. It is vital that the user be familiar with his firearm and possible safety risks that may be present in the design. Most significantly, the user should realize that the designs of safeties - or even the presence of adequate safeties - vary significantly on historical designs and do not offer the protection against accidental discharge that modern firearms safeties achieve.

Similarly, any firearm that is designed to be fired using black powder (or Pyrodex) has basic risks not found in modern cartridge firearms. Black powder is a dangerous explosive and has to be used and handled with extreme caution. The slightest miscalculation or carelessness with black powder firearms can result in serious injuries to the user.

**SHARPS 1863 Sporting - Black Powder**

Codes: 910.010/011/.012/.013/.019/.020/  
.021/.022/.024/.029/.030/.035/.036

Code	Dr. Ref.	DESCRIPTION	Qty	Code	Dr. Ref.	DESCRIPTION	Qty
<b>K710.073</b>	<b>2</b>	<b>BARREL 30" .54</b>	<b>1</b>	721.073	65	rear trigger spring	1
<b>K710.074</b>	<b>2</b>	<b>BARREL 32" .54</b>	<b>1</b>	730.213	64	front guard screw	1
<b>K710.081</b>	<b>2</b>	<b>BARREL 30" .451</b>	<b>1</b>	<b>O98.124</b>		<b>SINGLE SET TRIGGER ASSEMBLY</b>	<b>1</b>
770.180	1	Front sight	1	770.101	26	trigger guard plate	1
770.087	41	barrel lug	1	790.134	28	trigger	1
<b>O98.134</b>		<b>RECEIVER ASSEMBLY</b>	<b>1</b>	730.244	27	trigger screw	1
770.076	17	receiver	1	790.135	29	trigger lock	1
730.202	43	lever pin plunger	1	760.050	25	trigger lock spring	1
720.031	42	lever pin plunger spring	1	730.180	24	trigger lock screw	1
730.203	16	lever pin plunger screw	1	730.203	30	trigger lock spring screw	1
730.229	13	creedmoore sight base holes	1	<b>O98.062</b>		<b>STOCK ASSEMBLY</b>	<b>1</b>
<b>O98.135</b>		<b>BLOCK + LEVER ASSEMBLY</b>	<b>1</b>	780.018	22	STOCK ASSEMBLY	1
770.084	38	lever	1	760.048	21	butt plate	1
770.085	36	link	1	730.209	20	butt plate screw	2
730.298	35	link to breech block screw	1	730.208	18	side plate screw washer	1
770.090	34	breech block	1	<b>O98.064</b>		<b>SNABBLE FOREND ASSY</b>	<b>1</b>
730.255	37	link to lever screw	2	780.019	45	snabble forend	1
730.227	33	little nipple	1	730.208	18	forend screw washer	2
730.064	57	nipple	1	730.240	39	forend screw	2
730.228	23	breech block clean out screw	1	<b>O98.038</b>		<b>REAR SIGHT COMPLETE – octag.</b>	<b>1</b>
<b>O98.030</b>		<b>LOCK ASSEMBLY BLACK POWDER</b>	<b>1</b>	730.214	8	rear sight spring screw	1
790.146	53	side plate	1	790.121	11	rear sight base	1
790.119	54	hammer	1	790.136	7	rear sight leaf	1
770.080	48	tumbler	1	790.123	5	rear sight slide	1
770.082	30	stirrup	1	130.021	3	friction sphere	1
730.204	31	stirrup screw	1	720.032	4	rear sight slide spring	1
770.081	47	bridle	1	790.122	10	rear sight spring	1
730.201	46	tumbler screw	1	730.291	9	r. sight leaf pin to r. sight spring	1
770.083	49	fly	1	730.215	6	rear sight slide retainer screw	1
730.205	55	hammer screw	1	<b>O98.136</b>		<b>FINAL ASSEMBLY COMPONENTS</b>	
730.206	51	main spring retatner	1	730.207	19	side plate screw	2
721.075	52	main spring	1	730.210	15	rear tang screw	1
770.088	50	sear	1	730.213	23	front guard screw	2
<b>O98.007</b>		<b>DOUBLE SET TRIGGER ASSEMBLY</b>	<b>3</b>	730.209	20	rear guard screw/ butt plate	1
770.181	59	double set trigger guard plate	1	730.231	14	front tag screw / Stecher	1
730.232	58	rear trigger regulating screw	1	730.246	14	front tag screw / single trigger	1
730.233	57	regultaing screw	1	<b>730.272</b>	<b>12</b>	<b>floating chamber CAL.451</b>	<b>1</b>
130.030	56	trigger pin	1	<b>730.230</b>	<b>12</b>	<b>floating chamber CAL.54</b>	<b>1</b>
790.124	62	front trigger	1	<b>770.124</b>	<b>32</b>	<b>breech block flange CAL.451</b>	<b>1</b>
790125	66	rear trigger	1	<b>770.116</b>	<b>32</b>	<b>breech block flange CAL.54</b>	<b>1</b>
721072	60	front trigger spring	1	721.069	40	lever spring	1
730.214	61	front trigger spring screw	1	770.178	44	receiver lever pin	1

**List of parts  
1863 Sharps Sporting black powder**

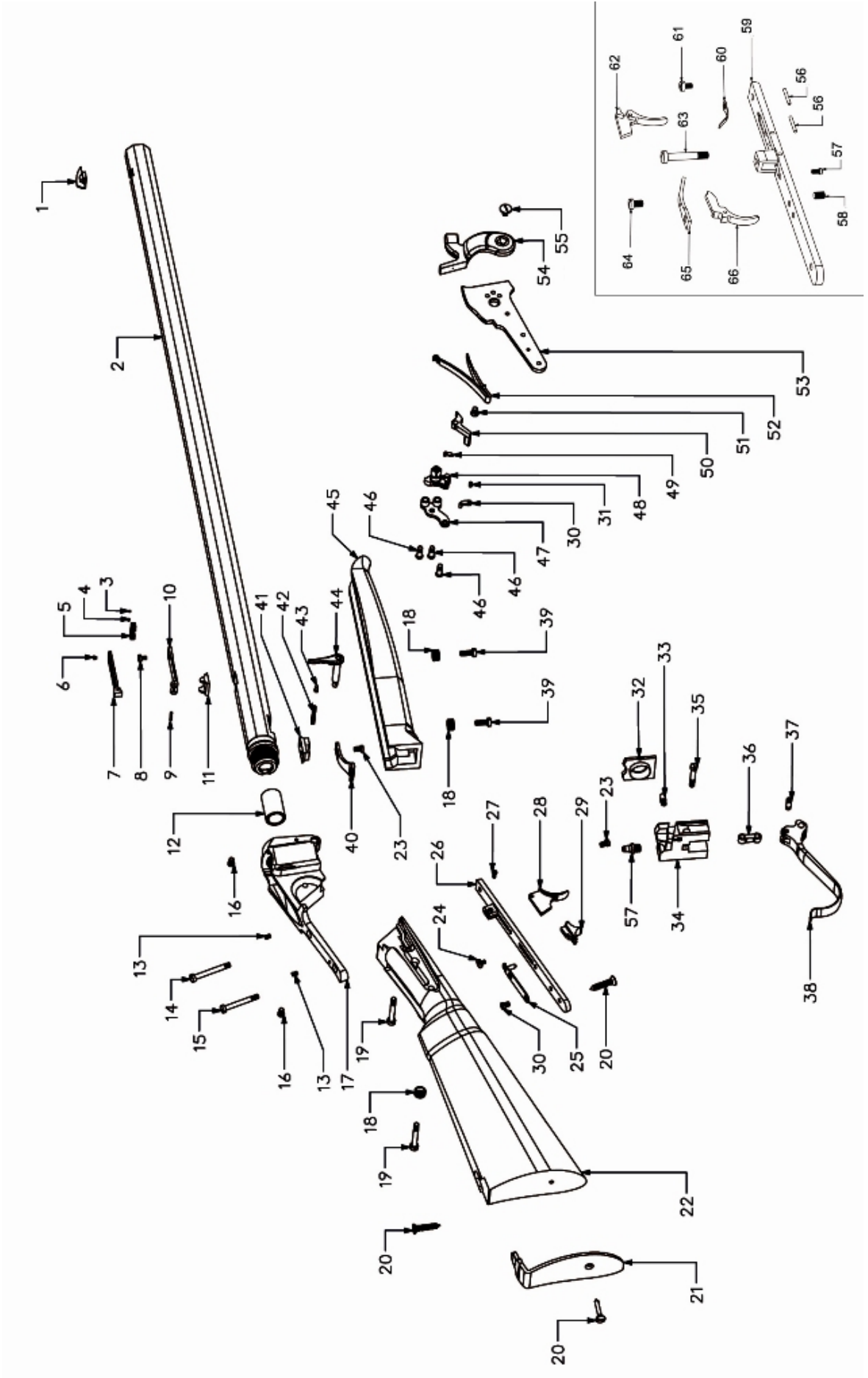

## SHARPS 1859 Cavalry Black Powder – Single Trigger

Code 910.014/015

Code	Dr. Ref.	DESCRIPTION	Qty	Code	Dr. Ref.	DESCRIPTION	Qty
<b>K710.077</b>	<b>4</b>	<b>BARREL CAVALRY 22"</b>	1	790.156	45	rear sight leaf	1
770.112	71	front sight	1	790.123	46	rear sight slide	1
770.087	43	barrel lug	1	130.021	47	friction ball	1
<b>O98.147</b>		<b>COMPLETE RECEIVER</b>	1	720.032	48	rear sight slide spring	1
770.198	5	receiver	1	790.147	49	rear sight spring	1
730.202	6	lever pin plunger	1	730.291	50	r. sight leaf pin to r. sight spring	1
720.031	7	lever pin plunger spring	1	730.215	51	rear sight slide retainer screw	1
730.203	8	lever pin plunger screw	1	<b>O98.142</b>		<b>FINAL ASSEMBLY COMPONENTS</b>	<b>1</b>
730.229	9	creedmoore sight base holes	2	730.214	53	rear sight spring screw	1
<b>O98.135</b>		<b>COMPLETE BREECH BLOCK AND LEVER</b>	<b>1</b>	790.121	52	rear sight base	1
770.084	10	lever	1	730.088	60	saddle ring holder	1
770.085	11	link	1	730.207	38	side plate front screw	2
730.298	12	link to breech block screw	1	730.210	39	rear tang screw	1
770.090	13	breech block	1	730.213	31	front guard screw	2
730.255	18	link to lever screw	1	730.209	3	rear guard screw	1
730.227	14	littl nipple	1	730.246	41	front tang screw	1
730.064	15	nipple	1	730.240	56	forend screw	2
730.228	16	breech block clean out screw	1	730.257	44	floating chamber	1
<b>O98.030</b>		<b>LOCK COMPLETE</b>	1	770.116	17	breech block flange	1
790.146	19	side plate	1	721.069	42	lever spring	1
790.119	20	hammer	1	770.178	40	receiver lever spring	1
770.080	21	tumbler	1	721.076	58	barrel band spring	1
770.082	29	stirrup	1	770.114	59	saddle ring	1
730.204	30	stirrup screw	1	770.115	61	saddle ring plate	1
770.081	22	bridle	3	790.126	57	barrel band	1
730.201	23	tumbler screw	1	<b>O98.144</b>		<b>BUTTSTOCK COMPLETE (with patchbox)</b>	<b>1</b>
770.083	24	fly	1	780.024	62	stock	1
730.205	25	hammer screw	1	760.047	63	butt plate	1
730.206	26	main spring retainer screw	1	730.209	3	rear guard screw	2
721.075	27	main spring	1	<b>O98.127</b>		<b>SHARPS PATCHBOX</b>	<b>1</b>
770.088	28	sear	1	721.074	66	patchbox spring	1
<b>O98.124</b>		<b>TRIGGER GUARD COMPLETE</b>	1	730.214	53	patchbox spring screw	1
770.101	32	trigger guard plate	1	770.097	64	patchbox	1
790.134	34	trigger	1	770.096	65	patchbox hinge	1
730.244	33	trigger screw	1	790.131	68	stop patch box spring	1
790.135	35	trigger lock	1	180.001	69	pins for patch box stop	2
760.050	37	trigger lock spring	1	125.000	70	wood patch box screws	3
730.180	36	trigger lock screw	1	730.085	67	Trigger plate screw	1
730.203	8	trigger lock spring screw	1	<b>O98.143</b>		<b>BUTTSTOCK COMPLETE (no patchbox)</b>	<b>1</b>
<b>O98.145</b>		<b>COMPLETE FOREND</b>	1	780.022	54	forend	1
780.022	54	forend	1	780.023	1	stock	1
730.208	55	side plate screw washer	1	760.048	2	butt plate	1
O98.040		COMPLETE REAR SIGHT	1	730.209	3	rear guard screw	2



**SHARPS 1859 Infantry - Black Powder**

Single trigger : Codes 910.016, 910.017, 910.027, 910.028

Code	Dr. Ref.	DESCRIPTION	Qty	Code	Dr. Ref.	DESCRIPTION	Qty
<b>K710.052</b>	<b>13</b>	<b>BARREL INFANTRY 30 " .54</b>	<b>1</b>	790131	10	stop patch box spring	1
<b>K710.086</b>	<b>13</b>	<b>BARREL INFANTRY 30 " .451</b>	<b>1</b>	125.000	12	wood patch box screws	3
770.112	73	front sight	<b>1</b>	<b>O98.139</b>		<b>COMPLETE FOREND</b>	<b>1</b>
770.087	52	barrel lug	1	780.034	61	forend	1
<b>O98.134</b>		<b>COMPLETE RECEIVER</b>	1	730.208	2	side plate screw	1
770.076	14	receiver	<b>1</b>	770.095	62	nose cap	1
730.202	15	lever pin plunger	1	730.214	7	nose cap screw	1
720.031	16	lever pin plunger spring	1	<b>O98.039</b>		<b>COMPLETE REAR SIGHT</b>	<b>1</b>
730.203	17	lever pin plunger screw	1	790.136	54	rear sight leaf	1
730.229	18	creedmoore sight base holes	2	790123	55	rear sight slide	1
<b>O98.135</b>		<b>COMPLETE BREECH BLOCK</b>	1	130.021	56	friction ball	1
		<b>AND LEVER</b>	<b>1</b>	720.032	57	rear sight slide spring	1
770.084	19	lever	1	790.147	58	rear sight spring	1
770.085	20	link	1	730.291	59	rear sight leaf pin to rear sight spring	1
730.298	21	link to breech block screw	1	730.215	60	rear sight slide retainer screw	1
770.090	22	breech block	1	<b>O98.140</b>		<b>COMPLETE MIDDLE BAND</b>	<b>1</b>
730.255	27	link to lever screw	1	790.127	66	barrel band middle	1
730.227	23	little nipple	1	790.129	67	swivel band	1
730.064	24	nipple	1	730.250	68	swivel belt screw	1
730.228	25	breech block clean out screw	1	<b>O98.141</b>		<b>COMPLETE SWIVELT BELT BASE</b>	<b>1</b>
<b>O98.030</b>		<b>LOCK COMPLETE</b>	<b>1</b>	790.130	71	swivelt belt base	1
790.146	28	side plate	1	790.129	67	swivel band	1
790.119	29	hammer	1	730.250	68	swivel belt screw	1
770.080	30	tumbler	1	730.078	72	trigger guard screw	1
770.082	38	stirrup	1	<b>O98.142</b>		<b>FINAL ASSEMBLY OMPONENTS</b>	<b>1</b>
730.204	39	stirrup screw	1	730.214	7	rear sight spring screw	1
770.081	31	bridle	3	790.121	63	rear sight base	1
730.201	32	tumbler screw	1	790.126	65	barrel band rear	1
770.083	33	fly	1	730.207	47	lock plate screw	2
730.205	34	hammer screw	1	730.210	48	rear tang screw	1
730.206	35	main spring retainer	1	730.213	40	front guard screw	2
721.075	36	main spring	1	730.209	4	rear guard screw/ butt plate	1
770.088	37	sear	1	730.246	50	front tag screw (single trigger)	1
<b>O98.124</b>		<b>TRIGGER GUARD COMPLETE</b>	1	730.240	64	forend screw	1
770.101	41	trigger guard plate	1	730.230	53	floating chamber .54	1
790.134	43	trigger	1	<b>730.272</b>	<b>53</b>	<b>floating chamber .451</b>	<b>1</b>
730.244	42	trigger screw	1	<b>770.124</b>	<b>26</b>	<b>breech block flange .451</b>	<b>1</b>
790.135	44	trigger lock	1	770.116	26	breech block flange .54	1
760.050	46	trigger lock spring	1	721.069	51	lever spring	1
730.180	45	trigger lock screw	1	770.178	49	receiver lever pin	1
730.203	17	trigger lock spring screw	1	790.128	69	barrel band front	1
<b>O98.138</b>		<b>BUTTSTOCK COMPLETE</b>	1	721.076	70	barrel band spring	3
		<b>with patchbox and swivel</b>	1	<b>O98.007</b>		<b>DOUBLE SET TRIGGER ASSEMBLY</b>	<b>1</b>
780.016	1	stock	1	730.213	40	front guard screw	1
730.208	2	side plate screw	2	770.181	74	double set trigger guard plate	1
760.047	3	butt plate	<b>1</b>	730.232	75	rear trigger regulating screw	1
730.209	4	rear guard screw/ butt plate	1	730.233	76	regulating screw	1
<b>O98.127</b>		<b>SHARPS PATCHBOX</b>	1	130.030	77	trigger pin	2
721.074	8	patch box spring	1	790.124	78	front trigger	1
730.214	7	patch box spring screw	1	790.125	79	rear trigger	1
770.097	5	patch box	1	721072	80	front trigger spring	1
770.096	6	patch box hinge		730214	7	front trigger spring screw	1
730.085	9	Trigger plate screw		721073	81	rear trigger spring	1
180001	11	pins for patch box stop	2	730231	82	Front tag screw (stecher)	1

**List of parts  
1859 Sharps Infantry black powder**

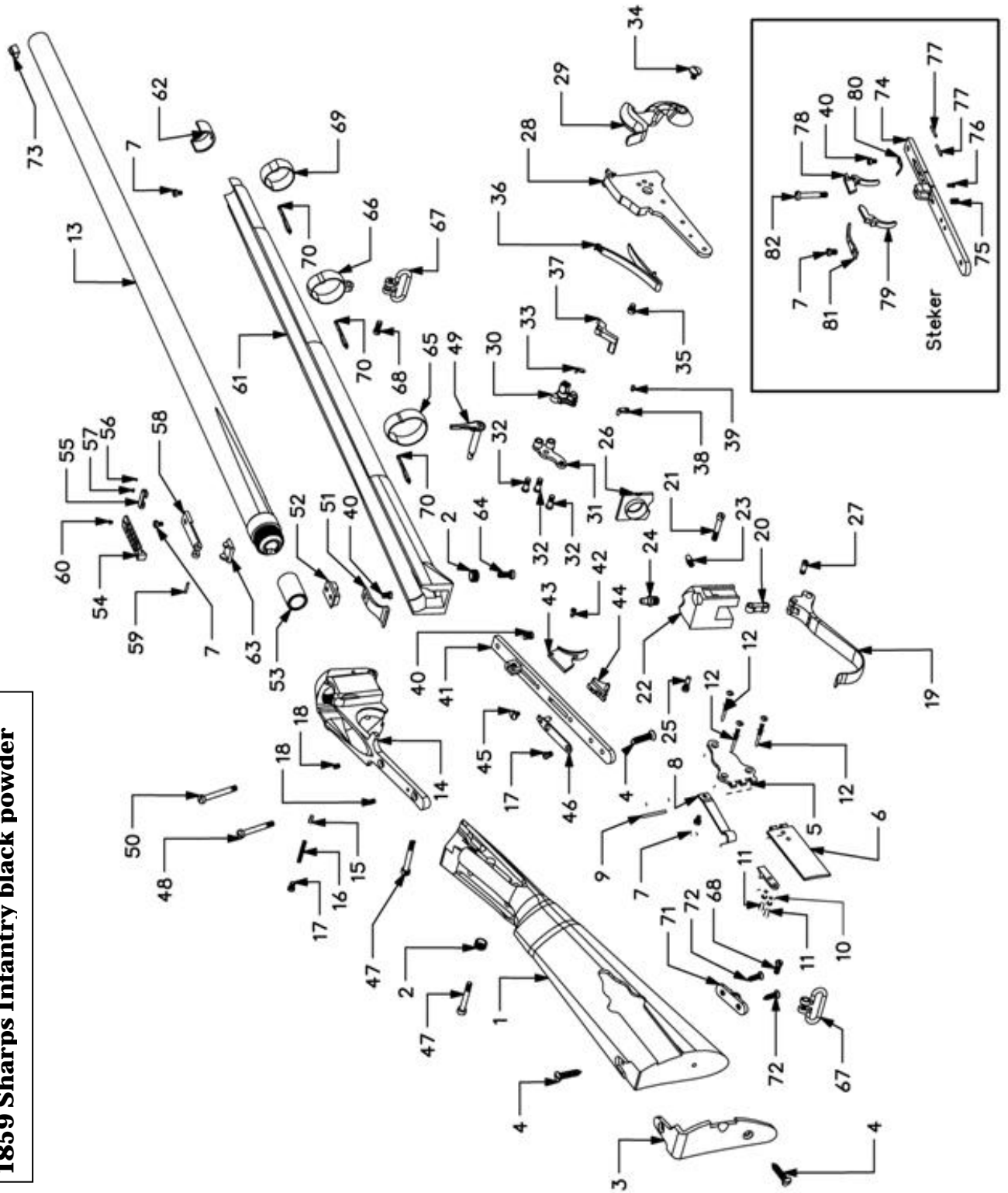

**SHARPS 1874 Sporting – Breech loading**

Codes: 920.000/.001/.002/.003/.004/.005/.006/.007/.008/.009/.010/.011/.012/.013/.014/  
.019/.020/.024/.025/.027/.031/.037/.046/.049/.050/.059/.110/.112/.114/.115/.156

Code	Draw. Ref.	DESCRIPTION	Qty	Code	Draw. Ref.	DESCRIPTION	Qty
<b>O98.062</b>		<b>STOCK ASSEMBLY</b>	<b>1</b>	760.050	25	trigger lock spring	1
780.018	22	stock	1	730.180	24	trigger lock screw	1
760.048	21	butt plate	1	730.203	16	trigger lock spring screw	1
730.209	20	butt plate screw	2	<b>O98.007</b>		<b>DOUBLE SET TRIGGER ASSEMBLY</b>	<b>1</b>
730.208	18	side plate screw washer	1	730.213	64	front guard screw	1
<b>710.053</b>	<b>2</b>	<b>BARREL 30" 45/70</b>	<b>1</b>	770.181	59	double set trigger guard plate	1
<b>710.051</b>	<b>2</b>	<b>BARREL 32" 45/70</b>	<b>1</b>	730.232	58	rear trigger regulating screw	1
<b>710.058</b>	<b>2</b>	<b>BARREL 32" 40/65</b>	<b>1</b>	730.233	57	regulating screw	1
<b>710.061</b>	<b>2</b>	<b>BARREL 32" 45/90</b>	<b>1</b>	130.030	56	trigger pin	2
<b>710.158</b>	<b>2</b>	<b>BARREL 32" 45/110</b>	<b>1</b>	790.124	62	front trigger	1
<b>710.063</b>	<b>2</b>	<b>BARREL 32" 45/120</b>	<b>1</b>	790.125	66	rear trigger	1
<b>710.159</b>	<b>2</b>	<b>BARREL 32" 50/90</b>	<b>1</b>	721.072	60	front trigger spring	1
<b>710.067</b>	<b>2</b>	<b>BARREL 34" 45/70</b>	<b>1</b>	730.214	61	front trigger spring screw	1
<b>710.062</b>	<b>2</b>	<b>BARREL 34" 45/90</b>	<b>1</b>	721.073	65	rear trigger spring	1
<b>710.064</b>	<b>2</b>	<b>BARREL 34" 45/120</b>	<b>1</b>	<b>O98.065</b>		<b>SHARPS PARTS OF ENSEMBLE</b>	<b>1</b>
770.087	41	barrel lug	1	730.207	19	side plate screw	2
770.180	1	Sharps blade front sight	1	730.210	15	rear tang screw	1
<b>O98.000</b>		<b>RECEIVER ASSEMBLY</b>	<b>1</b>	770.178	44	receiver lever pin	1
770.078	17	receiver - cartridge	1	730.231	14	front tang screw	1
730.202	43	lever pin plunger	1	721.069	40	lever spring	1
720.031	42	lever pin plunger spring	1	730.213	27	front guard screw	1
730.203	16	lever pin plunger screw	1	790.133	12	extractor	1
<b>730.229</b>	<b>13</b>	<b>CREEDMOORE SIGHT BASE HOLES SCREW</b>	<b>2</b>	730.209	20	butt plate screw	2
<b>O98.019</b>		<b>BLOCK + LEVER ASSEMBLY</b>	<b>1</b>	<b>O98.125</b>		<b>SHARPS PARTS OF ENSEMBLE</b>	<b>1</b>
770.084	38	lever	1	730.207	19	side plate screw	2
770.085	36	link	1	730.210	15	rear tang screw	1
730.298	37	link to breech block screw	1	770.178	44	receiver lever pin	1
770.098	34	breech block - cartridge	1	730.246	14	front tang screw	1
790.132	31	firing pin pusher	1	721.069	40	lever spring	1
730.491	32	firing pin	1	730.213	27	front guard screw	1
<b>730.241</b>	<b>32</b>	<b>FIRING PIN before serial No. SH6309</b>	<b>1</b>	790.133	12	extractor	1
720.033	33	firing pin spring	1	730.209	20	butt plate screw	2
730.242	30	firing pin screw	1	<b>O98.038</b>		<b>REAR SIGHT COMPLETE - octagonal</b>	<b>1</b>
730.255	35	link to lever screw	1	730.214	8	rear sight spring screw	1
<b>O98.031</b>		<b>LOCK ASSEMBLY - CARTRIDGE</b>	<b>1</b>	790.121	11	rear sight base	1
790.160	53	lock plate	1	790.136	7	rear sight leaf	1
790.120	54	hammer	1	790.123	5	rear sight slide	1
770.080	44	tumbler	1	130.021	3	friction sphere	1
770.082	56	stirrup	1	720.032	4	rear sight slide spring	1
730.204	57	stirrup screw	1	790.122	10	rear sight spring	1
770.081	47	bridle	1	730.291	9	r. sight leaf pin to r. sight spring	1
730.201	46	bridle screw	3	730.215	6	rear sight slide retainer screw	1
770.083	49	fly	1	<b>O98.064</b>		<b>SNABBLE FOREND ASSY</b>	<b>1</b>
730.205	55	hammer screw	1	780.019	45	snabble forend	1
730.206	51	main spring retainer screw	1	730.208	18	forend screw washer	2
721.075	52	main sprig	1	730.240	39	forend screw	2
770.088	50	sear	1	<b>O98.146</b>		<b>HARTFORD STYLE FOREND ASSY</b>	<b>1</b>
<b>O98.124</b>		<b>SINGLE SET TRIGGER ASSEMBLY</b>	<b>1</b>	780.027	77	Hartford style forend	1
770.101	26	trigger guard plate	1	730.208	76	forend screw washer	2
790.134	28	trigger	1	<b>O98.126</b>		<b>STOCK FOR PATCHBOX ASSY</b>	<b>1</b>
730.244	27	trigger screw	1	780.021	67	stock with patch box cut	1
790.135	29	trigger lock	1	760.047	74	butt plate	1
730.209	75	butt plate screw	2	730.214	73	patch box spring screw	1
125.000	69	patch box screw	3	770.097	68	patch box	1
<b>O98.127</b>		<b>SHARPS PATCHBOX</b>	<b>1</b>	770.096	70	patch box hinge	1
721.074	72	patch box spring	1	730.085	71	Trigger plate screw	1

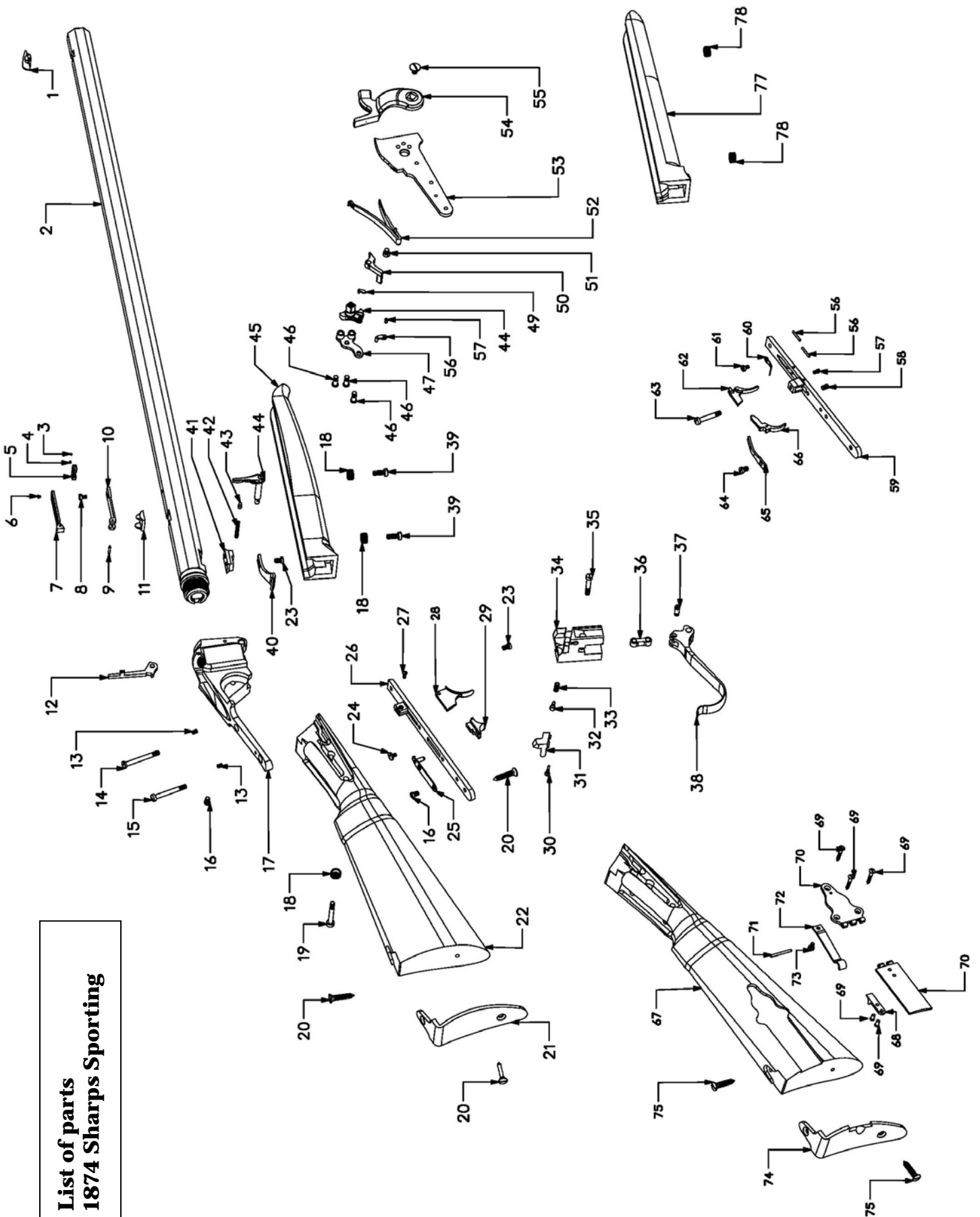

List of parts  
1874 Sharps Sporting

**SHARPS 1874 Sporting Quigley**

Cod. 920.028/.029/.030/.040/.044/.045/.096

Code	Draw. Ref.	DESCRIPTION	Qty	Code	Draw. Ref.	DESCRIPTION	Qty
710.078	2	Octagonal BRL 34" cal. 45/70	1	730.233	57	Regulating screw	1
710.083	2	Octagonal BRL 34" cal. 45/90	1	130.030	56	Trigger pin	2
710.084	2	Octagonal BRL 34" cal. 45/120	1	790.124	62	Front trigger	1
710.118	2	Octagonal BRL 34" cal. 45/110	1	790.125	66	Rear trigger	1
710.127	2	Octagonal BRL 34" cal. 50/90	1	721.072	60	Front trigger spring	1
710.204	2	Octagonal BRL 34" cal. 38/55 W	1	730.214	61	Front trigger spring screw	1
730.208	18	Side plate screw washer	1	721.073	65	Rear trigger spring	1
770.087	41	Barrel lug	1	<b>O98.065</b>		<b>SHARPS PARTS OF ENSEMBLE</b>	<b>1</b>
770.180	1	Sharps blade front sight	1	730.207	19	Side plate screw	2
<b>O98.000</b>		<b>RECEIVER ASSEMBLY</b>	<b>1</b>	730.210	15	Rear tang screw	1
770.078	17	Receiver-cartridge	1	770.178	44	Receiver lever pin	1
730.202	43	Lever pin plunger	1	730.231	14	Front tang screw	1
720.031	42	Lever pin plunger spring	1	721.069	40	Lever spring	1
730.203	16	Lever pin plunger screw	1	730.213	27	Front guard screw	1
730.229	13	Sight base hole screw	2	790.133	12	Extractor	1
<b>O98.019</b>		<b>BLOCK + LEVER ASSEMBLY</b>	<b>1</b>	730.209	20	Butt plate screw	2
770.084	38	Lever	1	780.031	77	Snabble forend	1
770.085	36	Link	1	730.208	76	Forend screw washer	2
730.298	37	Link to breech block screw	1	<b>O98.038</b>		<b>REAR SIGHT comp.for octag.BRL</b>	<b>1</b>
770.098	34	Breech block - cartridge	1	730.214	8	Rear sight spring screw	1
790.132	31	Firing pin pusher	1	790.121	11	Rear sight base	1
730.491	32	Sharps firing pin	1	790.136	7	Rear sight leaf	1
720.033	33	Firing pin spring	1	790.123	5	Rear sight slide	1
730.242	30	Firing pin screw	1	130.021	3	Friction sphere	1
730.255	35	Link to lever screw	1	720.032	4	Rear sight slide spring	1
<b>O98.031</b>		<b>LOCK ASSEMBLY - CARTRIDGE</b>	<b>1</b>	790.122	10	Rear sight spring	1
790.160	53	Lock plate	1	730.291	9	Rear sight leaf pin to r.s. spring	1
790.120	54	Hammer	1	730.215	6	Rear sight slide retainer screw	1
770.080	44	Tumbler	1	730.240	39	Forend screw	2
770.082	56	Stirrup	1	<b>O98.126</b>		<b>STOCK FOR PATCHBOX ASSY</b>	<b>1</b>
730.204	57	Stirrup screw	1	780.021	67	Sporting stock with patchbox	1
770.081	47	Bridle	1	760.047	74	Butt plate	1
730.201	46	Bridle screw	3	125.000	69	Patch box screw	3
770.083	49	Fly	1	<b>O98.127</b>		<b>SHARPS PATCHBOX</b>	<b>1</b>
730.205	55	Hammer screw	1	721.074	72	Patch box spring	1
730.206	51	Main spring retainer screw	1	730.214	73	Patch box spring screw	1
721.075	52	Main spring	1	770.097	68	Patch box	1
770.088	50	Sear	1	770.096	70	Patch box hinge	1
<b>O98.007</b>		<b>DOUBLE SET TRIGGER ASSEMBLY</b>	<b>1</b>	730.085	71	Trigger plate screw	1
730.213	64	Front guard screw	1	790.131	68	Stop patch box spring	1
770.181	59	Double set trigger guard plate	1	180.001	69	Pins for patch box stop	2
730.232	58	Rear trigger regulating screw	1				

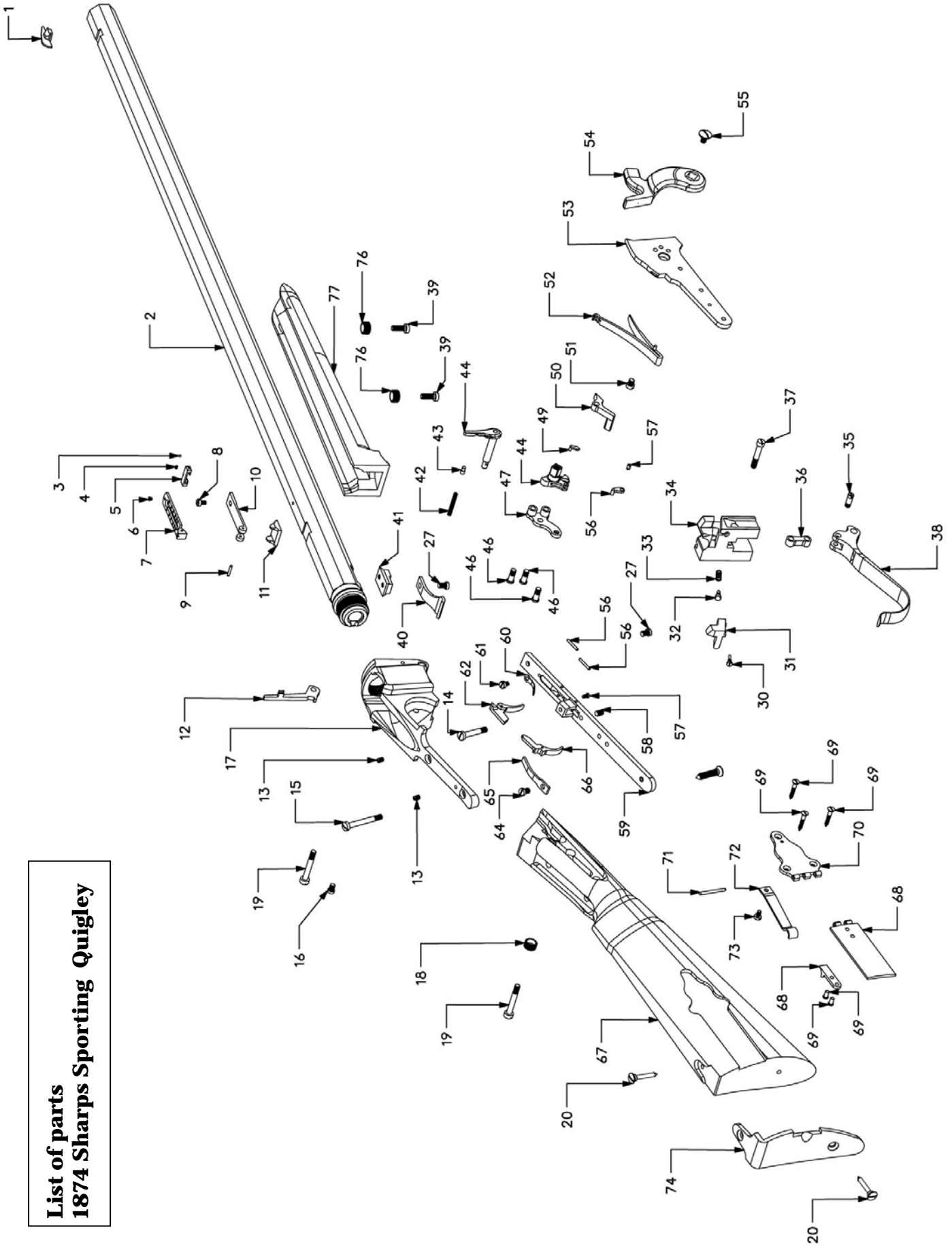

**List of parts  
1874 Sharps Sporting Quigley**

**SHARPS Creedmoor 34” 45/70**

Cod. 920.164

Code	Dr. Ref.	DESCRIPTION	Qty	Code	Dr. Ref.	DESCRIPTION	Qty
<b>O98.246</b>		<b>STOCK ASSEMBLY</b>	<b>1</b>	730.214	61	front trigger spring screw	1
780.072	22	stock	1	721.073	65	rear trigger spring	1
270.027	21	butt plate	1	<b>O98.133</b>		<b>FINAL ASSY COMPONENTS</b>	<b>1</b>
730.209	20	butt plate screw	2	730.207	19	side plate screw	2
730.208	18	side plate screw washer	1	730.394	15	rear tang screw	1
770.348	24	stock grip plate	1	770.178	44	receiver lever pin	1
125.000	25	grip plate screw	1	730.231	14	front tang screw	1
130.029	26	grip plate pin	1	721.069	40	lever spring	1
<b>710.194</b>	<b>2</b>	<b>BARREL 34" 45/70</b>	<b>1</b>	730.213	27	front guard screw	1
<b>O98.291</b>		<b>RECEIVER ASSEMBLY</b>	<b>1</b>	790.133	12	extractor	1
770.078	17	receiver - cartridge	1	770.087	41	Barrel lug, burnished	1
730.202	43	lever pin plunger	1	730.209	20	butt plate screw	1
720.031	42	lever pin plunger spring	1	<b>O98.245</b>		<b>COMPLETE FOREND</b>	<b>1</b>
730.203	16	lever pin plunger screw	1	780.068	45	snabble forend	1
<b>O98.019</b>		<b>BLOCK + LEVER ASSEMBLY</b>	<b>1</b>	730.208	18	forend screw washer	2
770.084	38	lever	1	770.395	13	nose cap	<b>1</b>
770.085	36	link	1	730.717	23	nose cap screw	1
730.298	37	link to breech block screw	1	730.240	39	forend screw	2
770.098	34	breech block - cartridge	1	<b>970.073</b>		<b>Level front sight</b>	<b>1</b>
790.132	31	firing pin pusher	1	160.003	80	o-ring	2
730.491	32	firing pin	<b>1</b>	721.094	77	tunnel front sight spring	1
720.033	33	firing pin spring	1	730.382	79	ring nut for level fronth sight	2
730.242	30	firing pin screw	1	730.383	76	spring screw for front sight	1
730.255	35	link to lever screw	1	770.175	1	front sight frame	1
<b>O98.031</b>		<b>LOCK ASSEMBLY - CARTRIDGE</b>	<b>1</b>	970.072	81	level	1
790.160	53	lock plate	1	760.115	78	level leaf	1
790.120	54	hammer	1	<b>O98.249</b>		<b>SHORT diopter ASSY</b>	<b>1</b>
770.080	48	tumbler	1	730.033	70	special screw	1
770.082	56	stirrup	1	730.016	6	endless screw support	1
730.204	57	stirrup screw	1	770.003	29	diopter vertical slide	1
770.081	47	bridle	1	730.013	28	diopter lock knob	1
730.201	46	bridle screw	3	730.015	7	ring nut for diopter device	1
770.083	49	fly	1	730.011	5	knob for diopter angle regulation	1
730.205	55	hammer screw	1	730.019	9	diopter spring block screw	1
730.206	51	main spring retainer screw	1	770.005	3	diopter base	1
721.075	52	main spring	1	721.016	10	diopter special spring	1
770.088	50	sear	1	730.012	72	knob for diopter horiz. regulation	1
<b>O98.131</b>		<b>TRIGGER GUARD ASSY - PISTOL GRIP</b>	<b>1</b>	140.001	71	elastic ring	1
730.213	64	front guard screw	1	770.002	63	diopter horiz. Ruler	1
770.173	59	double set trigger guard plate	1	770.000	69	diopter horiz. Key	1
730.232	58	rear trigger regulating screw	1	730.021	8	diopter endless screw	1
730.233	67	regulating screw	1	<b>730.028</b>	<b>82</b>	diopter fixing screw M4	<b>2</b>
130.030	68	trigger pin	2	<b>730.029</b>	<b>82</b>	diopter fixing screw UNF	<b>2</b>
790.124	62	front trigger	1	O98,169	4	leaf for short diopter	1
790.125	66	rear trigger	1	730.014	11	diopter parabole hole 1 mm	1
721.072	60	front trigger spring	1				

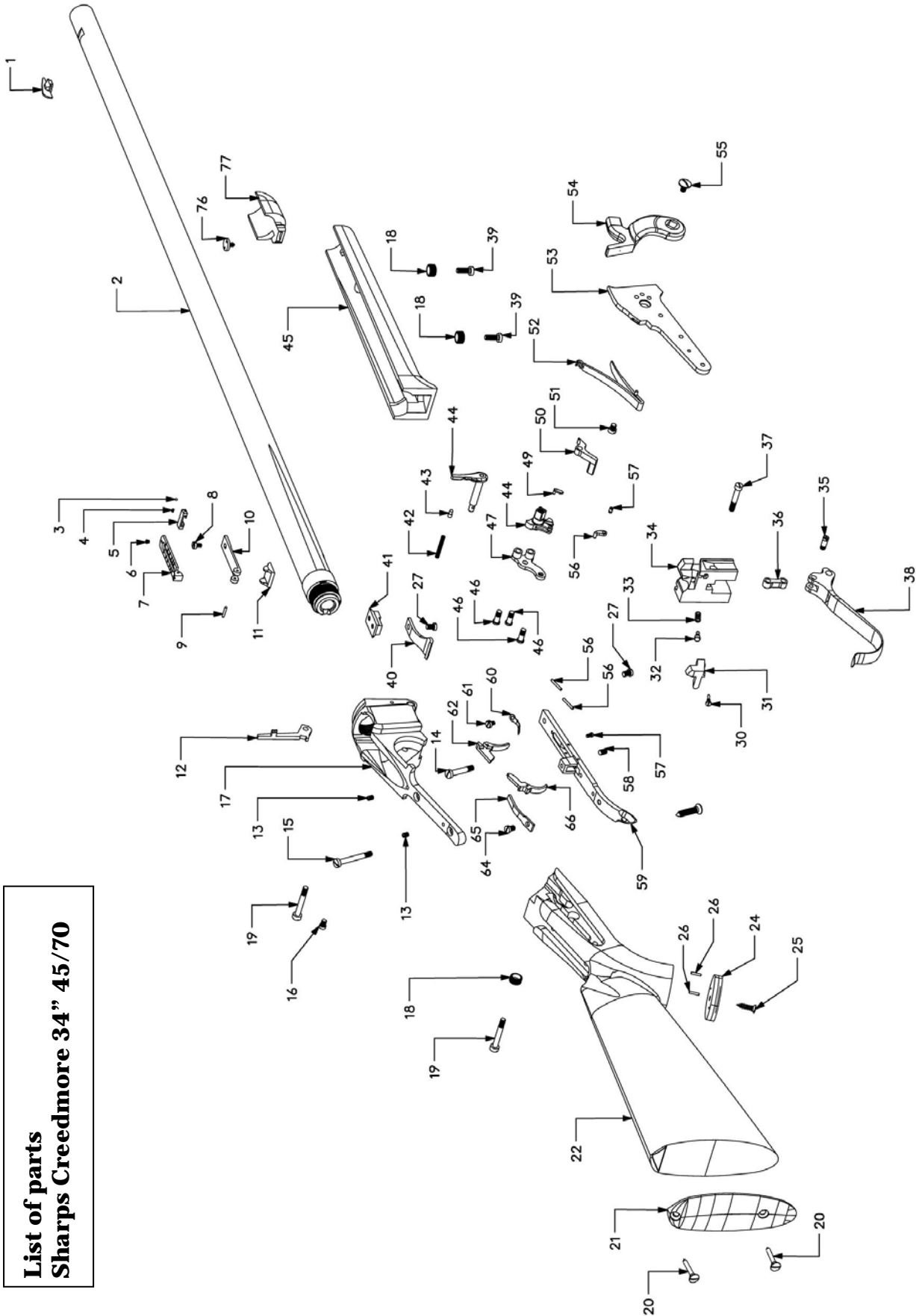

**List of parts  
Sharp's Creedmore 34" 45/70**

**1874 Sharps Cavalry**

Cod. 920.017/920.055

Code	Dr. Ref.	DESCRIPTION	Qty	Code	Dr. Ref.	DESCRIPTION	Qty
<b>K710.072</b>	<b>4</b>	<b>BARREL CAVALRY 22" 45/70</b>	1	790135	35	trigger lock	1
<b>K710.129</b>	<b>4</b>	<b>BARREL CAVALRY 22" 50/70</b>	1	760.050	37	trigger lock spring	1
770.112	62	front sight	1	730.180	36	trigger lock screw	1
770.087	43	barrel lug	1	730.203	8	trigger lock spring screw	1
<b>O98.149</b>		<b>COMPLETE RECEIVER</b>	1	<b>O98.145</b>		<b>COMPLETE FOREND</b>	1
770.199	5	receiver	1	780.022	54	forend	1
730.202	6	lever pin plunger	1	730.208	55	side plate screw washer	1
720.031	7	lever pin plunger spring	1	<b>O98.040</b>		<b>COMPLETE REAR SIGHT</b>	<b>1</b>
730.203	8	lever pin plunger screw	1	790.156	45	rear sight leaf	1
730.229	9	creedmoore sight base holes	2	790.123	46	rear sight slide	1
<b>O98.019</b>		<b>BLOCK + LEVER ASSEMBLY</b>	1	130.021	47	friction ball	1
770.084	10	lever	1	720.032	48	rear sight slide spring	1
770.085	11	link	1	790.147	49	rear sight spring	1
730.298	12	link to breech block screw	1	730.291	50	r. sight leaf pin to r. sight spring	1
770.098	13	breech block - cartridge	1	730.215	51	rear sight slide retainer screw	1
790.132	14	firing pin pusher	1	<b>O98.125</b>		<b>FINAL ASSEMBLY COMPONENTS</b>	<b>1</b>
730.491	15	firing pin	1	730.088	60	saddle ring holder	1
730.241	15	firing pin before ser.num SH6309	1	730.207	38	side plate front screw	2
720.033	16	firing pin spring	1	730.210	39	rear tang screw	1
730.242	17	firing pin screw	1	730.213	31	front guard screw	2
730.255	18	link to lever screw	1	730.209	3	rear guard screw	1
<b>O98.031</b>		<b>LOCK ASSEMBLY - CARTRIDGE</b>	1	730.246	41	front tang screw	1
790.160	19	lock plate	1	730.240	56	forend screw	1
790.120	20	hammer	1	721.069	42	lever spring	1
770.080	21	tumbler	1	770.178	40	receiver lever spring	1
770.082	29	stirrup	1	<b>790.133 44</b>		<b>EXTRACTOR</b>	<b>1</b>
730.204	30	stirrup screw	1	<b>770.203 44</b>		<b>EXTRACTOR .50/90</b>	<b>1</b>
770.081	22	bridle	1	770.114	59	saddle ring	1
730.201	23	bridle screw	3	770.115	61	saddle ring plate	1
770.083	24	fly	1	<b>O98.143</b>		<b>BUTTSTOCK COMPLETE (w.patchbx)</b>	<b>1</b>
730.205	25	hammer screw	1	780.023	1	stock	1
730.206	26	main spring retainer screw	1	760.048	2	butt plate	1
721.075	27	main spring	1	730.209	3	rear guard screw	2
770.088	28	sear	1	730.240	56	forend screw	1
<b>O98.124</b>		<b>TRIGGER GUARD COMPLETE</b>	1	730.214	53	patch box spring screw	1
770.101	32	trigger guard plate	1	790.126	57	barrel band	1
790.134	34	trigger	1	721.076	58	barrel band spring	1
730.244	33	trigger screw	1	790.121	52	rear sight base	1

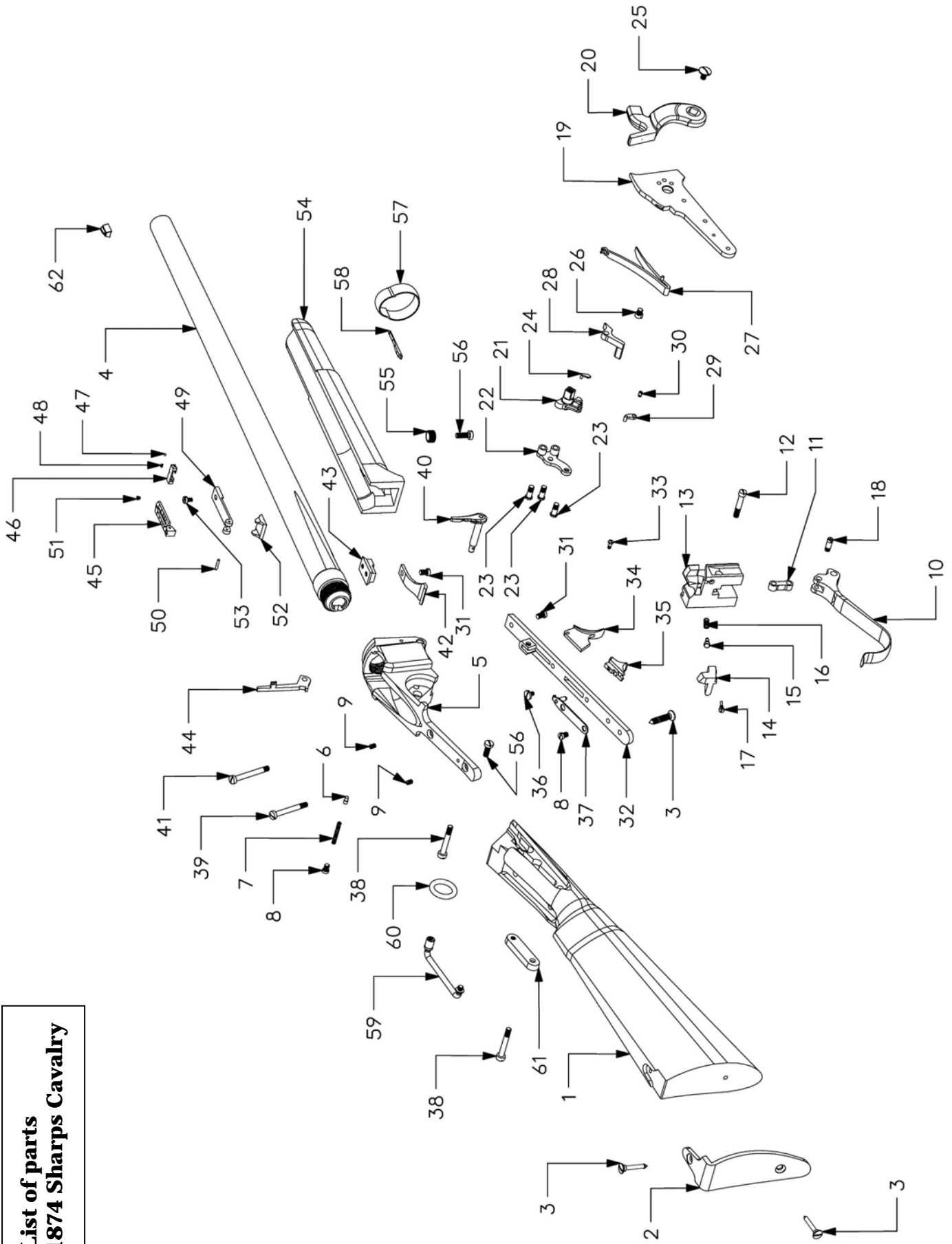

**List of parts  
1874 Sharps Cavalry**

**1874 Sharps Infantry**

Code 920.015 – single trigger; Code 920.016 – double trigger

Code	Dr. Ref.	DESCRIPTION	Qty	Code	Dr. Ref.	DESCRIPTION	Qty
<b>710.071</b>	<b>13</b>	<b>BARREL INFANTRY 30 " 45/70</b>	1	130.030	77	trigger pin	2
770.112	73	front sight	1	790.124	78	front trigger	1
770.087	52	barrel lug	1	790.125	79	rear trigger	1
<b>O98.000</b>		<b>COMPLETE RECEIVER</b>	1	721.072	80	front trigger spring	1
770.078	14	receiver	1	730.214	7	front trigger spring screw	1
730.202	15	lever pin plunger	1	721.073	81	rear trigger spring	1
720.031	16	lever pin plunger spring	1	<b>O98.065</b>		<b>SHARPS PARTS OF ENSEMBLE</b>	<b>1</b>
730.203	17	lever pin plunger screw	1	730.207	47	SIDE PLATE SCREW	2
730.229	18	creedmoore sight base holes	2	730.210	48	rear tang screw	1
<b>O98.138</b>		<b>BUTTSTOCK COMPLETE</b>	1	770.178	49	RECEIVER LEVER PIN	1
		<b>WITH PATCHBOX AND SWIVEL</b>		730231	82	front tang screw	1
780.016	1	stock	1	721.069	51	lever spring	1
730.208	2	side plate screw	1	730.213	40	front guard screw	2
760.047	3	butt plate	1	790.133	53	EXTRACTOR	1
730.209	4	rear guard screw/ butt plate	2	730.209	4	BUTT PLATE SCREW	1
<b>O98.127</b>		<b>SHARPS PATCHBOX</b>	<b>1</b>	<b>O98.039</b>		<b>COMPLETE REAR SIGHT</b>	<b>1</b>
721.074	8	patch box spring	1	790.136	54	rear sight leaf	1
730.214	7	PATCH BOX SPRING SCREW	1	790.123	55	rear sight slide	1
770.097	5	PATCH BOX	1	130.021	56	friction ball	1
770.096	6	PATCH BOX HINGE	1	720.032	57	rear sight slide spring	1
730.085	9	Trigger plate screw	1	790.147	58	rear sight spring	1
790.131	10	stop patch box spring	1	730.214	7	nose cap screw	1
180.001	11	pins for patch box stop	2	730.291	59	rear sight leaf pin to rear sight spring	1
125.000	12	wood patch box screws	3	730.215	60	rear sight slide retainer screw	1
<b>O98.019</b>		<b>BLOCK + LEVER ASSEMBLY</b>	1	<b>O98.139</b>		<b>COMPLETE FOREND</b>	<b>1</b>
770.084	19	lever	1	780.034	61	forend	1
770.085	20	link	1	730.208	2	side plate screw	1
730.298	21	link to breech block screw	1	770.095	62	nose cap	1
770.098	22	breech block - cartridge	1	730.214	7	nose cap screw	1
790.132	23	firing pin pusher	1	730.240	64	forend screw	1
730.491	24	firing pin	1	790.126	65	barrel band rear SH	1
730.241	24	firing pin before ser.num SH6309	1	<b>O98.140</b>		<b>COMPLETE MIDDLE BAND</b>	<b>1</b>
720.033	25	firing pin spring	1	790.127	66	barrel band middle	1
730.242	26	firing pin screw	1	790.129	67	swivel band	1
730.255	27	link to lever screw	1	730.250	68	swivel belt screw	1
<b>O98.031</b>		<b>LOCK ASSEMBLY - CARTRIDGE</b>	1	790.128	69	Barrel band front SH Infantry	1
790.160	28	lock plate	1	721.076	70	Barrel band spring SH	3
790.120	29	hammer	1	<b>O98.141</b>		<b>COMPLETE SWIVELT BELT BASE</b>	<b>1</b>
770.080	30	tumbler	1	790.130	71	swivelt belt base	1
770.082	38	stirrup	1	790.129	67	swivel band	1
730.204	39	stirrup screw	1	730.250	68	swivel belt screw	1
770.081	31	bridle	1	730.078	72	trigger guard screw	2
730.201	32	bridle screw	3	790.121	63	rear sight base	1
770.083	33	fly	1	<b>O98.124</b>		<b>TRIGGER GUARD COMPLETE</b>	<b>1</b>
730.205	34	hammer screw	1	770.101	41	trigger guard plate	1
730.206	35	main spring retainer screw	1	790.134	43	trigger	1
721.075	36	main spring	1	730.244	42	trigger screw	1
770.088	37	sear	1	790.135	44	trigger lock	1
<b>O98.007</b>		<b>DOUBLE SET TRIGGER ASSEMBLY</b>	1	760.050	46	trigger lock spring	1
730.213	40	font guard screw	1	730.180	45	trigger lock screw	1
770.181	74	double set trigger guard plate	1	730.203	17	trigger lock spring screw	1
730.232	75	rear trigger regulating screw	1	730.246	50	REAR TANG SCREW single trigger	1
730.233	76	regulating screw	1				

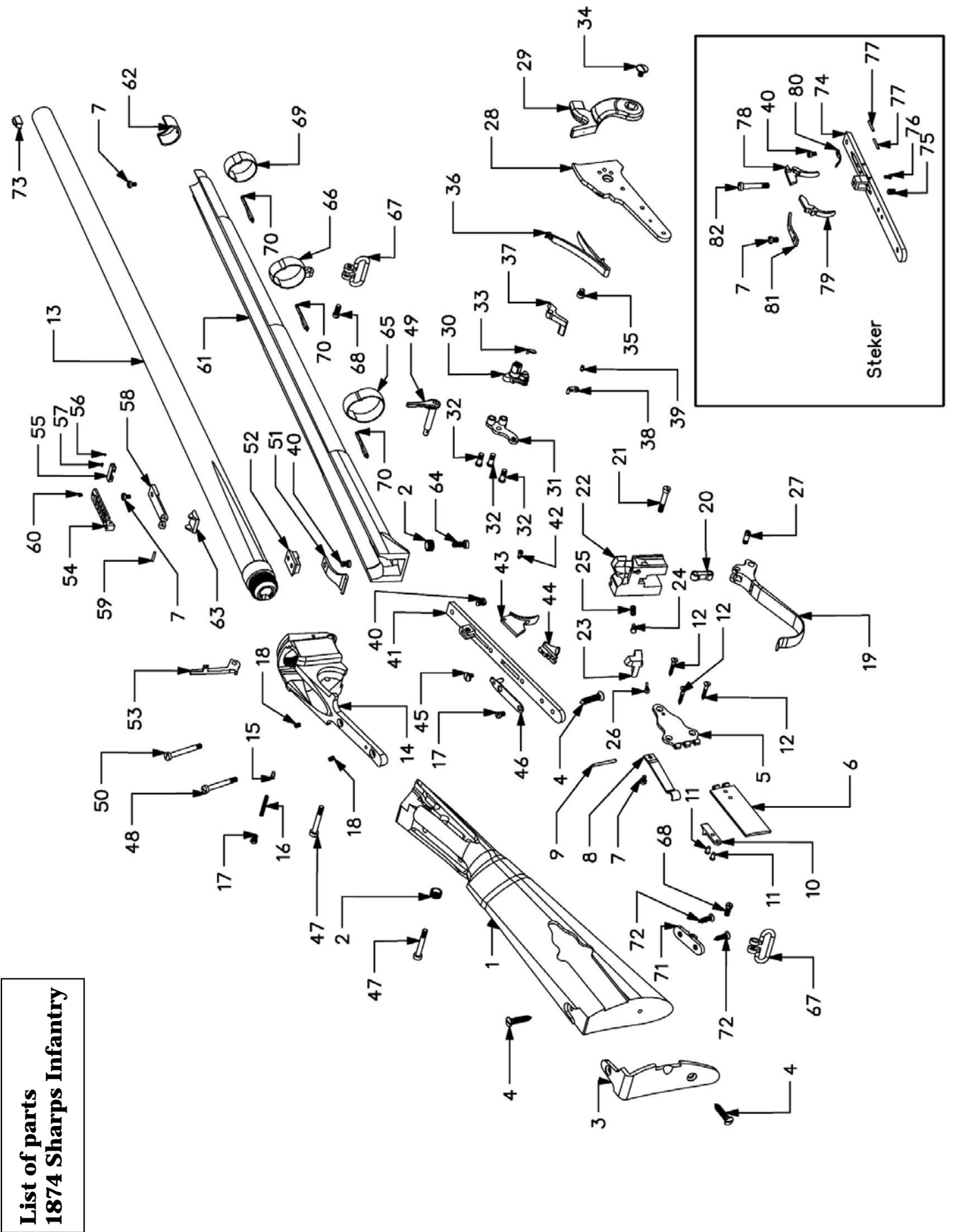

**List of parts  
1874 Sharps Infantry**

**1874 Sharps Texas Cavalry**

Cod. 920.047/920.048

Code	Dr. Ref.	DESCRIPTION	Qty	Code	Dr. Ref.	DESCRIPTION	Qty
<b>710.072</b>	<b>4</b>	<b>Barrel 22" cal. 45/70</b>	<b>1</b>	730.244	33	trigger screw	1
<b>710.129</b>	<b>4</b>	<b>Barrel 22" cal. 50/70</b>	<b>1</b>	790.135	35	trigger lock	1
770.112	62	Front sight, round barrel	1	760.050	37	trigger lock spring	1
770.087	43	Barrel lug	1	730.180	36	trigger lock screw	1
<b>O98.152</b>		<b>RECEIVER ASSEMBLY</b>	<b>1</b>	730.203	8	trigger lock spring screw	1
770.200	5	Receiver Sharps Texas Cavalry	1	<b>O98.145</b>		<b>SNABBLE FOREND ASSY</b>	<b>1</b>
730.202	6	lever pin plunger	1	780.022	54	Snabble forend	1
720.031	7	lever pin plunger spring	1	730.208	55	Forend screw washer	1
730.203	8	lever pin plunger screw	1	<b>O98.040</b>		<b>REAR SIGHT COMPLETE</b>	<b>1</b>
730.229	9	Dioptre hole screw	2	790.156	45	Rear sight leaf	1
<b>O98.019</b>		<b>BLOCK + LEVER ASSEMBLY</b>	<b>1</b>	790.123	46	Rear sight slide	1
770.084	10	lever	1	130.021	47	Friction sphere	1
770.085	11	link	1	720.032	48	Rear sight slide spring	1
730.298	12	link to breech block screw	1	790.147	49	Rear sight spring	1
770.098	13	breech block - cartridge	1	730.291	50	R.sight leaf pin to r.sight spring	1
790.132	14	firing pin pusher	1	730.215	51	Rear sight slide retainer screw	1
730.491	15	firing pin	1	<b>O98.125</b>		<b>SHARPS PARTS OF ENSEMBLE</b>	<b>1</b>
720.033	16	firing pin spring	1	730.088	60	saddle ring holder	1
730.242	17	firing pin screw	1	730.207	38	side plate screw	2
730.255	18	link to lever screw	1	730.210	39	rear tang screw	1
<b>O98.153</b>		<b>LOCK ASSEMBLY - CARTRIDGE</b>	<b>1</b>	730.213	31	front guard screw	2
790.171	19	lock plate	1	730.209	3	rear guard screw/ butt plate	1
790.172	20	hammer	1	730.246	41	front tag screw	1
770.080	21	tumbler	1	730.240	56	forend screw	1
770.082	29	stirrup	1	721.069	42	lever spring	1
730.204	30	stirrup screw	1	770.178	40	receiver lever pin	1
770.081	22	bridle	1	<b>790.133</b>	<b>44</b>	<b>Extractor cal. 45</b>	<b>1</b>
730.201	23	bridle screw	3	<b>770.203</b>	<b>44</b>	<b>Extractor cal. 50/90</b>	<b>1</b>
770.083	24	fly	1	770.114	59	saddle ring	1
730.205	25	hammer screw	1	770.115	61	saddle ring plate	1
730.206	26	main spring retainer screw	1	<b>O98.143</b>		<b>BUTTSTOCK Sharps Cavalry</b>	<b>1</b>
721.075	27	main spring	1	780.023	1	Stock Sharps Cavalry	1
770.088	28	sear	1	760.048	2	butt plate	1
760.096	63	Paper cutter plate	1	730.209	3	butt plate screw	2
130.033	64	Cutter plate pin	1	730.240	56	forend screw	1
730.213	31	front guard screw	1	730.214	53	Rear sight spring screw	1
<b>O98.124</b>		<b>SINGLE SET TRIGGER ASSEMBLY</b>	<b>1</b>	790.126	57	Barrel band, rear, Sharps Infantry	1
770.101	32	trigger guard plate	1	721.076	58	Barrel band spring SH	1
790.134	34	trigger	1	790.121	52	rear sight base	1

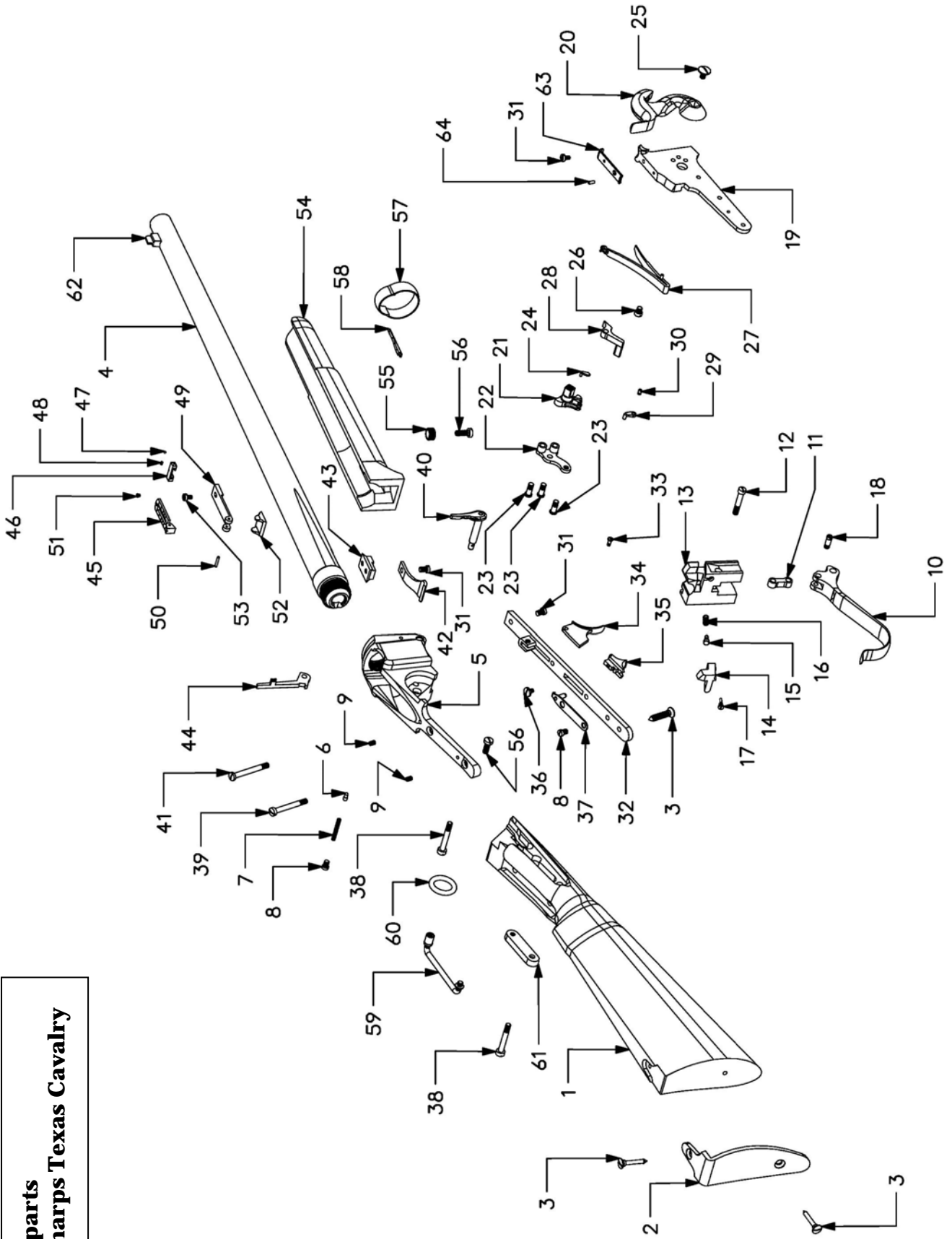

**List of parts  
1874 Sharps Texas Cavalry**

**Mini Sharps**

Cod. 920.187/.188/.189/.190/.191/.192/.194/.196/.197/.208

Code	Dr. Ref.	DESCRIPTION	Qty	Code	Dr. Ref.	DESCRIPTION	Qty
<b>O98.256</b>		Stock Assembly	1	770382	38	Sear	1
780.075	1	Stock	1	<b>O98.007</b>		<b>Double Set Trigger Assembly</b>	<b>1</b>
790.199	4	Butt Plate	2	730.695	8	front guard screw	1
730.209	5	Butt Plate Screw	1	770.390	46	double set trigger guard plate	1
730.694	10	Butt Plate Screw Washer	1	730.703	44	rear trigger regulating screw	1
<b>710.214</b>	<b>3</b>	<b>Barrel 26" 45 LC</b>	<b>1</b>	730.233	45	regulating screw	2
<b>710.215</b>	<b>3</b>	<b>Barrel 26" 44/40W</b>	<b>1</b>	130.062	43	trigger pin	1
<b>710.211</b>	<b>3</b>	<b>Barrel 26" 38/55W</b>	<b>1</b>	770.379	42	front trigger	1
<b>710.217</b>	<b>3</b>	<b>Barrel 26" 30/30W</b>	<b>1</b>	790.378	41	rear trigger	1
<b>710.212</b>	<b>3</b>	<b>Barrel 26" 22Hornet</b>	<b>1</b>	721.127	48	front trigger spring	1
<b>710.219</b>	<b>3</b>	<b>Barrel 24" 22WinMag</b>	<b>1</b>	730.704	49	front trigger spring screw	1
<b>710.213</b>	<b>3</b>	<b>Barrel 24" 22 LR</b>	<b>1</b>	721.123	47	Trigger Spring	2
<b>710.217</b>	<b>3</b>	<b>Barrel 26" 30-30WIN</b>	<b>1</b>	730.708	11	side plate screw	1
<b>710.220</b>	<b>3</b>	<b>Barrel 24" 17 HMR</b>	<b>1</b>	730.706	12	rear tang screw	1
<b>710.227</b>	<b>3</b>	<b>Barrel 26" 218Bee</b>	<b>1</b>	770.392	28	receiver lever pin	1
<b>O98.259</b>		<b>Receiver Assembly</b>		730.705	13	front tang screw	1
770.368	25	Receiver	1	721.122	7	lever spring	2
730.700	27	lever pin plunger	1	730695	8	front guard screw	1
720.004	24	lever pin plunger spring	1	770.408	18	Extractor 44/40 45LC	1
730.699	23	lever pin plunger screw	1	770.373	18	Extractor 38-55W	1
<b>O98.260</b>		<b>Breech Block Assembly (Center Fire)</b>	<b>1</b>	770.409	18	Extractor 22Hornet	1
<b>O98.277</b>		<b>Breech Block Assembly (Rimfire)</b>	<b>1</b>	770.410	18	Extractor 22LR	1
770.375	26	Lever	1	770.424	18	Extractor 22 Win Mag	1
770.374	22	Link	1	730.078	61	Guard Stock Screw	1
730.698	19	link to breech block screw	1	770.369	6	Barrel Lug	4
770.370	17	Breech Block (Center Fire)	1	730.749	62	Scope Base Plug Screw	1
770.411	17	Breech Block (Rimfire)	1	<b>O98.257</b>		<b>Tang Sight Assembly</b>	<b>1</b>
770.371	14	firing pin punsher	1	730.716	58	Diopter (Eyepeice) Spring screw	1
730.696	15	Firing Pin (Center Fire)	1	770.386	53	Sight base	1
730.748	15	Firing Pin (Rimfire)	1	770.387	54	Sight Staff	1
720.007	16	Firing Pin Spring	1	770.388	56	Diopter (Eye Piece) Back	1
730.697	21	Breech Block Plate	1	730714	55	Diopter (Eye Piece)	1
730.702	20	link to lever screw	1	730.713	59	Lateral Base Screw	1
730.770	63	Breech Block Plate Screw	1	721.125	60	Sight Staff Spring	2
<b>O98.261</b>		<b>Lock Plate Assembly</b>	<b>1</b>	730.715	57	Base Screw	1
770.383	31	Lock Plate	1	<b>O98.265</b>		<b>Forend Assembly</b>	<b>1</b>
790.200	30	Hammer	1	780.076	2	Forend (Standard)	2
770.381	37	Tumbler	1	730.694	10	Forend Screw Washer	2
770.385	36	Stirrup	1	730.693	9	Forend Screw	1
730.710	34	Stirrup Screw	1	<b>O98.264</b>		<b>Front sight Assembly</b>	<b>1</b>
770.380	39	Bridle	3	730.481	50	Front Sight Screw	1
730.709	40	Bridle Screw	1	760.105	51	Front Sight Blade	1
770.384	35	Fly	1	770.223	52	Front Sight Base	1
730.712	29	Hammer Screw	1				
730.711	32	main spring retainer screw	1				
721.124	33	main spring	1				

**Mini Sharps  
Components**

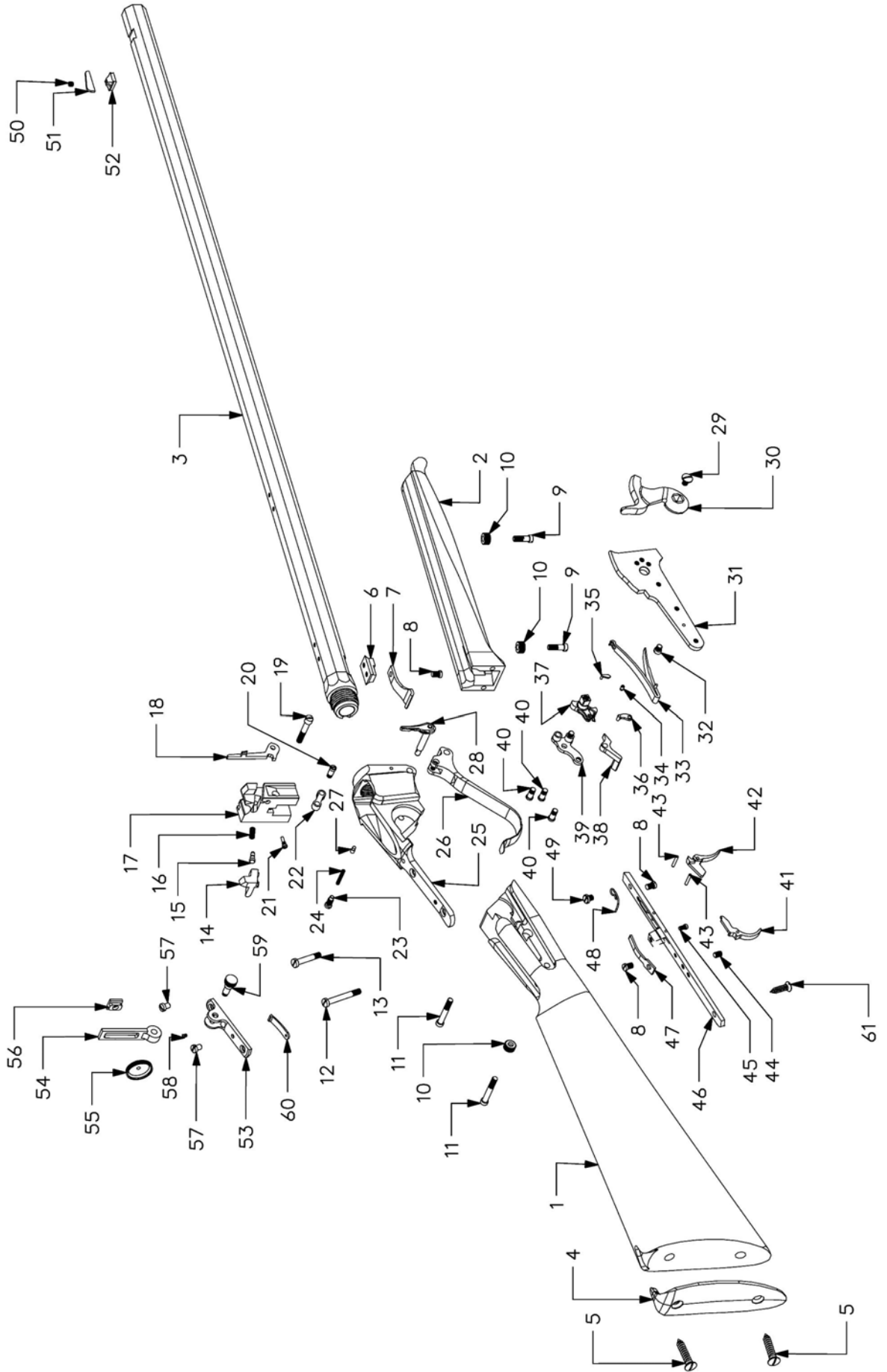

## GUARANTEE CONDITIONS

Armi Sport guarantees that our products are scrupulously checked against defects in materials, workmanship and aesthetical and functioning problems.

In case you find a defect in one of our products, you should immediately contact the DEALER/SHOP/GUNSMITH where you have bought your gun. The seller will indicate the conditions for the repair, which will be either made directly by them or through our assistance.

**ATTENTION: end users are not allowed to ship any gun directly to Armi Sport for repair, either under guarantee or against payment. Transportation of weapons is strictly regulated and the documents which are required can solely be issued by companies with specific authorization.**

1. Armi Sport will warrant for structural or project defects without any time limit.
2. Armi Sport guarantees, for a year after the purchase date, the free substitution of parts for defects which have been found out also during use: wear of parts which shouldn't be subject to wear, or excessive wear of parts subject to wear. The customer will have to give evidence of the purchase date with a bill or other valid proof.
3. In case the defect under cover of guarantee is not repairable, Armi Sport will provide for a free substitution of the weapon.

ARMI SPORT RESERVES THE INSINDACABLE FACULTY OF DEFINING THE TYPE OF DEFECT OF THE WEAPON, AND THEREFORE TO STATE WHETHER THE DEFECT IS COVERED BY GUARANTEE –Armi Sport's decision will be fair but final.

Armi Sport will be allowed a timing of 60 days for repair under guarantee, and 90 days for free substitution.

We strongly recommend that you keep the receipt  
or proof of purchase for any Armi Sport product

### THE GUARANTEE IS VOID IN CASE:

- Inadequate ammunition has been used (any ammunition but those commonly on sale, reloaded ammunition, different from caliber and specification indicated on the gun barrel)
- The gun failed to be provided proper maintenance and cleaning
- The gun has been modified without our prior consent
- Unauthorized, inadequate or incorrect repairs have been carried out
- Parts subject to wear and corrosion
- Damage (improper use of the gun by the user)
- Expiry of the guarantee

In the above cases the repair, if carried out, will be charged to the customer

**The guarantee does not cover parts subject to wear and corrosion**

In case non original spare parts are used, the guarantee or any service contract with Armi Sport will be void.

**ATTENTION:** delivery expenses to and from the service center are not covered by the guarantee and will be charged to the customer.

In case, for any valid reason, you do not have the possibility to obtain repair under guarantee at the shop where you bought the gun, you may contact us directly; we will indicate a local dealer to support you with the repair file:

e-mail: [info@armichiappa.com](mailto:info@armichiappa.com) - Phone: +39/030/9749065  
USA: e-mail: [info@chiappafirearms.com](mailto:info@chiappafirearms.com) - Phone: 937-835-5000

**Should Armi Sport become aware of a defect of the rifle during the guarantee period, the defective part will be substituted free of charge.**

**This instruction manual must always follow the firearm, also in case the owner should change**

Procedure for the usage of the guarantee

BEFORE shipping the weapon back for repair, the customer should contact the gunshop where the product was bought. The customer should supply proper information on the defect, and the relevant file will then be started.

The gun shop will be given an “NDR” (Repair Number). The weapon will have to be shipped back to the gun shop in its original packing, with a copy of the purchase date, the Guarantee Form (attached) duly filed with indication of the NDR number, according to the instructions of the dealer.

**WARNING:** the returned gun must be protected with an adequate packaging; any damages occurred during transportation and handling will be the customer’s responsibility

## **Request form** **REPAIR UNDER GUARANTEE**

NdR NDR :

Please write in the above box the Repair Number you were given by the  
gun shop

### **1. Customer data:**

- Name: \_\_\_\_\_
- Address : \_\_\_\_\_
- Town : \_\_\_\_\_
- ZIP Code : \_\_\_\_\_
- Phone : \_\_\_\_\_ Available from \_\_\_\_ to \_\_\_\_
- Fax : \_\_\_\_\_

### **2. Product information:**

- Model : \_\_\_\_\_
- Serial number : \_\_\_\_\_

### **3. Gun Shop - dealer:**

- Purchase date : \_\_\_\_\_
- Dealer name : \_\_\_\_\_
- Dealer address : \_\_\_\_\_

### **4. Description of defect:**

---

---

---

---

Documents to enclose: Proof of the purchase date





**Armi Sport**

Armi Sport  
di Chiappa Silvia & C Snc  
Via Milano N°2 Azzano Mella (BS)  
Tel. 030 9749065 Fax 030 9749232  
[www.armochiappa.com](http://www.armochiappa.com)  
email: [info@armisport.com](mailto:info@armisport.com)



Kimar Srl  
Via Milano N°2 Azzano Mella (BS)  
Tel. 030 9749065 Fax 030 9749232  
[www.armochiappa.com](http://www.armochiappa.com)  
email: [info@armisport.com](mailto:info@armisport.com)



Chiappa Firearms, Ltd.  
530 N. Union Road  
Dayton, OH 45427 USA  
Tel. 937-954-1040  
[www.chiappafirearms.com](http://www.chiappafirearms.com)  
email: [info@chiappafirearms.com](mailto:info@chiappafirearms.com)